

Ontario Provincial Land Ambulance & Emergency Response Vehicle Standard

VERSION 4.1 – July 15, 2010

Emergency Health Services Branch
Ministry of Health and Long-Term Care

ONTARIO PROVINCIAL LAND AMBULANCE & EMERGENCY RESPONSE VEHICLE STANDARD

TABLE OF CONTENTS

<u>SECTION</u>	<u>SUBJECT</u>	<u>PAGE</u>
1.	<u>SCOPE OF THE STANDARD</u>	1
2.	<u>DEFINITIONS</u>	1
3.	<u>GENERAL REQUIREMENTS OF THE AMBULANCE</u>	4
4.	<u>AMBULANCE OWNER'S MANUAL</u>	5
5.	<u>MATERIALS</u>	5
5.1	<i>General</i>	5
5.2	<i>Insulation</i>	5
5.3	<i>Fastenings</i>	6
5.4	<i>Plywood</i>	6
5.5	<i>Interior Finishes</i>	6
6.	<u>EXTERIOR IDENTIFICATION</u>	6
6.1	<i>Objective</i>	6
6.2	<i>Identification Signage</i>	7
7.	<u>CONSTRUCTION AND DESIGN DETAILS</u>	7
7.1	<i>Safety by Design</i>	7
7.2	<i>General Construction Methods</i>	9
7.3	<i>Intentionally deleted</i>	9
7.4	<i>Cab Headliner</i>	9
7.5	<i>Patient Compartment Flooring</i>	9
7.6	<i>Bulkhead Partition</i>	10
7.7	<i>Patient Compartment Reinforcing Bar</i>	10
7.8	<i>Patient Compartment Side Door Step</i>	10
7.9	<i>Rear Step Bumper</i>	11
7.10	<i>Curb Clearance</i>	11

8.	<u>HEATING, VENTILATION AND AIR CONDITIONING</u>	12
9.	<u>LOW VOLTAGE (12V DC) CONVERSION ELECTRICAL SYSTEM</u>	13
9.1	<i>General</i>	13
9.2	<i>Electrical Load Isolation</i>	13
9.3	<i>Conversion Battery</i>	13
9.4	<i>Uninterruptible Conversion Power Circuits</i>	14
9.5	<i>Intentionally deleted</i>	14
9.6	<i>Fuses and Circuit Breakers</i>	14
9.7	<i>Driver's Switch Panel</i>	14
9.8	<i>Patient Compartment Switch Panel</i>	14
9.9	<i>Door Activated Switches</i>	14
9.10	<i>Door Ajar Light</i>	15
9.11	<i>Voltmeter</i>	15
9.12	<i>Two-Way Radio Power Supply</i>	15
9.13	<i>Patient Compartment Lighting</i>	15
9.14	<i>Incubator Receptacles</i>	16
9.15	<i>Cabinetry Lighting</i>	16
9.16	<i>Intentionally deleted</i>	16
9.17	<i>Intentionally deleted</i>	16
9.18	<i>Relays</i>	16
9.19	<i>Electrical Load Rating</i>	17
9.20	<i>Wiring</i>	17
9.21	<i>Intentionally deleted</i>	17
9.22	<i>Backup Warning Alarm</i>	17
10.	<u>EMERGENCY WARNING SYSTEM</u>	17
10.1	<i>Design Parameters</i>	17
10.2	<i>Forward Roof Warning Lights</i>	18
10.3	<i>Side and Rear Roof Level Warning Lights</i>	19
10.4	<i>Scene Lights</i>	19
10.5	<i>Grille Lights</i>	20
10.6	<i>Intersection Lights</i>	20
10.7	<i>Flash Patterns</i>	21
10.8	<i>Siren - Public Address System</i>	21
10.9	<i>Intentionally deleted</i>	22
10.10	<i>Traffic Directional Devices</i>	22
11.	<u>2-WAY RADIO INSTALLATIONS</u>	22
11.1	<i>General</i>	22
11.2	<i>Radio Equipment Mounting</i>	22
11.3	<i>Antennae Access</i>	23
11.4	<i>Antenna Ground Plane</i>	23
11.5	<i>Cable Routing</i>	24
11.6	<i>Installation of Radio Equipment</i>	24
12.	<u>OXYGEN SYSTEM</u>	25
12.1	<i>General</i>	25
12.2	<i>Oxygen Outlet(s)</i>	25

Ontario Provincial Land Ambulance & Emergency Response Vehicle Standard	iii
12.3 <u>Oxygen Cylinder Storage</u>	26
13. <u>SUCTION ASPIRATION SYSTEM</u>	26
14. <u>ACCOMMODATION AND STORAGE</u>	26
14.1 <u>General</u>	26
14.2 <u>Main Cot Mounting</u>	27
14.3 <u>Action Wall</u>	27
14.4 <u>Intentionally Deleted</u>	28
14.5 <u>Optional Squad Bench (Single Main Cot Ambulance)</u>	28
14.6 <u>Optional folding stretcher mounting</u>	28
14.7 <u>Squad Seat (Dual Main Cot Ambulance)</u>	30
14.8 <u>Auxiliary Seating (Dual Main Cot Ambulance)</u>	30
14.9 <u>Storage Requirements and Design</u>	30
14.10 <u>Optional Intravenous Holders</u>	31
14.11 <u>Waste Receptacles</u>	31
14.12 <u>Intentionally Deleted</u>	31
14.13 <u>Spare Tire Storage</u>	31
14.14 <u>Incubator Rear Tie-down</u>	32
15. <u>SAFETY EQUIPMENT</u>	32
15.1 <u>General</u>	32
15.2 <u>Bolsters</u>	32
15.3 <u>Grab Handles/Grab Rails</u>	33
15.4 <u>Reflective Safety Strips</u>	33
15.5 <u>Convex Mirrors</u>	33
15.6 <u>Fire Extinguishers</u>	33
15.7 <u>Passenger Restraint</u>	34
16. <u>INTERIOR SIGNS AND LABELS</u>	34
16.1 <u>General</u>	34
16.2 <u>Doors</u>	35
16.3 <u>Outlets</u>	35
16.4 <u>Intentionally deleted</u>	35
16.5 <u>Controls</u>	35
16.6 <u>Vehicle Height Indication</u>	35
16.7 <u>Weight Decal</u>	36
16.8 <u>Pressure Vessel Decal</u>	36
17. <u>MODULAR AMBULANCE BODY- TYPE 1 AND TYPE 3</u>	36
17.1 <u>General</u>	36
17.2 <u>Body Mounting</u>	36
17.3 <u>Doors</u>	36
17.4 <u>Windows</u>	37
17.5 <u>Door Latches</u>	37
17.6 <u>Electrical Ground</u>	37
18. <u>AMBULANCE CHASSIS SPECIFICATION</u>	37

18.1	<u>General</u>	37
18.2	<i>Intentionally Deleted</i>	38
18.3	<u>Payload Allowance</u>	38
18.4	<u>Electronic Equipment Interference</u>	38
19.	<u>CERTIFICATION OF AN AMBULANCE MODEL</u>	38
19.1	<u>General</u>	38
19.2	<u>Certificates and Reports</u>	40
19.3	<u>Certificate Distribution</u>	43
19.4	<u>Non-Compliant Vehicles</u>	43
19.5	<u>Continued Compliance</u>	44
19.6	<u>Compliance Review Program</u>	44
19.7	<u>Revocation and Suspension of an Ambulance Certification</u>	45
19.8	<u>Fees</u>	46
20.	<u>AMBULANCE PERFORMANCE STANDARDS</u>	47
20.1	<u>Main Cot Retention</u>	47
20.2	<u>Static Load Test for Ambulance Body Structures</u>	48
20.3	<u>HVAC Performance Tests</u>	53
20.4	<u>Pressure Vessel Retention</u>	56
20.5	<u>Interior Sound Level Test</u>	58
20.6	<u>Vehicle Weight Distribution</u>	60
20.7	<u>Centre of Gravity Location:</u>	63
20.8	<u>12 Volt dc Electrical System Performance</u>	64
20.9	<u>Electro Magnetic Radiation Suppression Test</u>	66
20.10	<u>Antennae Ground Plane Test:</u>	67
20.11	<u>Interior Lighting Test</u>	67
20.12	<u>Oxygen System Pressure Test</u>	68
20.13	<i>Intentionally Deleted</i>	69
20.14	<i>Intentionally Deleted</i>	69
20.15	<u>Body Door Components Test</u>	69
20.16	<u>Emergency Lighting Requirements</u>	70
20.17	<u>Carbon Monoxide Levels</u>	72
20.18	<u>Load Test for Grab Rail/Handles</u>	74
20.19	<u>Siren/Public Address System Sound Levels</u>	75
20.20	<u>Incubator Restraint Load</u>	76
20.21	<u>Passenger and Patient Safety Restraints Load</u>	77
20.22	<u>10 G restraint test</u>	77
20.23	<u>Occupant Restraint Load Test</u>	78
20.24	<u>Occupant Head Protection Zone</u>	79
ANNEX A		83
A1.	<u>SCOPE</u>	83
A2	<u>DEFINITIONS</u>	83
A3.	<u>GENERAL REQUIREMENTS</u>	83

A4.	<u>EXTERIOR IDENTIFICATION</u>	84
A4.1	<u>Objective</u>	84
A4.2	<u>Exterior Markings</u>	85
A5.	<u>EMERGENCY WARNING SYSTEM</u>	86
A5.1	<u>Design Parameters</u>	86
A5.2	<u>360 Degree Warning Lights</u>	87
A5.3	<u>Grille Lights</u>	87
A5.4	<u>Siren - Public Address System</u>	88
A5.5	<u>Backup Warning Alarm</u>	88
A6	<u>2-WAY RADIO INSTALLATIONS</u>	88
A6.1	<u>General</u>	88
A6.2	<u>Radio Equipment Mounting</u>	89
A6.3	<u>Antenna Ground Plane</u>	89
A6.4	<u>Cable Routing</u>	90
A6.5	<u>Installation of Radio Equipment</u>	90
A7.	<u>STORAGE</u>	90
A8.	<u>CERTIFICATION OF AN EMERGENCY RESPONSE VEHICLE</u>	91
A8.1	<u>General</u>	91
A8.2	<u>Certification</u>	91
A8.3	<u>Certificates and Reports</u>	92
A8.4	<u>Mandatory Testing for ERVs</u>	92
A8.5	<u>Continued Compliance</u>	92
		93
ANNEX B		96
REMOUNTED AMBULANCE		96
TRANSFER OF PATIENT COMPARTMENT MODULE		96
B1.	<u>SCOPE</u>	96
B2.	<u>GENERAL REQUIREMENTS</u>	96
B3.	<u>STRUCTURAL INTEGRITY</u>	97

B4. <u>MATERIAL CHANGES</u>	97
<i>B4.1 <u>Seats, Seat Belts & Other Occupant Safety Restraints:</u></i>	97
<i>B4.2 <u>Compartment Materials</u></i>	98
<i>B4.3 <u>Exterior Lights</u></i>	98
<i>B4.4 <u>Body Door Components:</u></i>	98
<i>B4.5 <u>Seat Travel</u></i>	98
B5. <u>CERTIFICATION</u>	99
ANNEX C	104
NEW AMBULANCE	104
COMPLIANCE CHECKLIST	104
ANNEX D	110
REMOUNTED AMBULANCES	110
ANNEX E	117
ERV	117
COMPLIANCE CHECKLIST	117
INDEX	119

Note: Changes in the requirements under the *Standard* between Version 4.0 and Version 4.1 have been identified with vertical change lines in the margin of the document.

**This page has been
left
intentionally blank**

ONTARIO PROVINCIAL LAND AMBULANCE & EMERGENCY RESPONSE VEHICLE STANDARD

1. SCOPE OF THE STANDARD

- 1.1 This *Standard* describes the minimum acceptable requirements for land ambulances for use by an operator of a land ambulance service.
- 1.2 Annex A of this *Standard* describes the minimum acceptable requirements for emergency response vehicles intended for use in ambulance services in the Province of Ontario.
- 1.3 Annex B of this *Standard* describes the minimum acceptable requirements for the transfer of a Patient Compartment Module to another chassis intended for use in ambulance services in the Province of Ontario.
- 1.4 Annex C of this *Standard* is the Compliance Checklist for a new ambulance.
- 1.5 Annex D of this *Standard* is the Compliance Checklist for a remounted ambulance.
- 1.6 Every operator of a land ambulance service shall be responsible for fully complying, or ensuring full compliance, with every provision of this *Standard*.

2. DEFINITIONS

- 2.1 "Ambulance" shall have the same meaning as this term has under the *Ambulance Act*, and the vehicles that are defined as ambulances under this *Standard* shall consist of the following types and shall be defined in the following way:
- (1) "Type 1 Ambulance", which shall mean " conventional truck cab and chassis with a remountable modular body that contains the patient compartment;

- (2) “Type 2 Ambulance” shall mean a standard van with integral cab and body, the patient compartment contained within the body and a raised roof over the patient compartment;
 - (3) "Type 3 Ambulance" shall mean a cutaway van cab and chassis with a remountable modular body that contains the patient compartment; and
 - (4) “Special Purpose Ambulance” shall mean any type of ambulance when built and equipped for a specific non-standard application. The design, construction, accommodation, safety and certification requirements shall be as approved by the director.
- 2.2 “AMD” shall mean the Ambulance Manufacturers’ Division of the National Truck Equipment Association.
- 2.3 “CMVSS” shall mean the Canadian Motor Vehicles Safety Standards.
- 2.4 "Contractor" shall mean the business entity or person undertaking the work of a new or remounted ambulance/ERV conversion. Applicable Compliance Checklist shall be completed by the Contractor.
- 2.5 "CSA" shall mean the Canadian Standards Association.
- 2.6 “C-UL” shall mean the Underwriters Laboratories of Canada.
- 2.7 “Director” shall mean the Director, Emergency Health Services Branch
- 2.8 "Emergency Response Vehicle" (ERV) shall have the same meaning as defined in the Ontario regulation 2.5.7/00
- 2.9 The term “heavy-duty” when used to describe an item shall mean in excess of the usual quality or capacity that is normally supplied as standard production material and represents the most durable item that is commercially available.

- 2.10 "ISO" shall mean the International Standards Organisation.
- 2.11 "Main Cot" shall mean a cot of a wheeled design adjustable to multi - levels and fully contoured for head and/or lower limb elevation as per the PES.
- 2.12 "Main Cot Retention System" shall mean a mechanical system, which provides means for securing a main cot to the floor and/or sidewall of an ambulance.
- 2.13 "OH&S" shall mean the Ontario Occupational Health and Safety Act and Regulations for Industrial Establishments.
- 2.14 "Original Equipment Manufacturer" (OEM) shall mean the manufacturer of the vehicle chassis used in the ambulance/ERV conversion.
- 2.15 "PES" shall mean the version of the 'Provincial Equipment Standards for Ontario Ambulance Services' which is in effect at the time of conversion of the ambulance/ERV.
- 2.16 The "Purchaser" shall mean the person, company, organisation, or body purchasing the new or remounted ambulance/ERV.
- 2.17 "Remount" shall mean an ambulance assembled using an existing patient compartment module on another chassis. Annex B contains the specific requirements for a remounted ambulance.
- 2.18 "SAE" shall mean the Society of Automotive Engineers.
- 2.19 "*Standard*" shall mean the current version of 'The Ontario Provincial Land Ambulance & Emergency Response Vehicle Standard'.
- 2.20 "HTA" shall mean the Ontario Highway Traffic Act

3. GENERAL REQUIREMENTS OF THE AMBULANCE

3.1 The ambulance shall comply with the following documents, listed in order of precedence:

- (1) the Canadian Motor Vehicle Safety Standards (CMVSS);
- (2) the Ontario Provincial Land Ambulance & Emergency Response Vehicle Standard (the *Standard*);
- (3) any criteria established by the OEM for the conversion of chassis to ambulances or emergency vehicles; and
- (4) all relevant Standards and Recommended Practices of technical agencies and bodies referred to in this *Standard*.

3.2 The documents referenced in paragraph 3.1 shall be the version of those documents that were in effect no earlier than when the motor vehicle chassis was manufactured and no later than when the vehicle was completed as an ambulance.

3.3 The ambulance shall be complete with the operating accessories as required herein; furnished with such modifications and attachments as may be necessary to enable the vehicle to function reliably and efficiently in its intended operating environment.

3.4 **Intentionally deleted**

3.5 All modifications or additions to the OEM chassis must be completed using approved OEM practices and all modified equipment must meet or exceed OEM performance characteristics.

3.6 The ambulance shall reflect the best standards of current industry practice with regard to workmanship and quality.

3.7 Any attached drawings, annexes and appendices shall form an integral part of this *Standard*.

3.8 When the ambulance is equipped with 110v electrical power, such installations shall be completed in accordance with the appropriate Ontario provincial hydro regulations for 110v installations in vehicles. An inspector certified under these regulations shall inspect the completed installation and an approved seal or certificate shall be affixed adjacent to the installation.

4. AMBULANCE OWNER'S MANUAL

4.1 Each ambulance shall be provided with an ambulance owner's manual that shall contain instructions on the operation, maintenance and repair of the ambulance and all installed equipment. The manual shall contain any relevant safety precautions for the ambulance or installed equipment.

4.2 Each ambulance shall be provided with a copy of all literature supplied with the chassis by the OEM chassis manufacture including the OEM owner's manual.

5. MATERIALS

5.1 General

No materials shall be used in the conversion that could result in an exposure to biological or chemical agents as defined in the related Occupational Health and Safety Regulations for Ontario and the Federal Hazardous Products Act.

NOTE: NO ASBESTOS OR PRODUCT USING ASBESTOS SHALL BE USED IN CONVERSION OF AMBULANCES.

5.2 Insulation

5.2.1 All insulation shall be non-toxic, non-settling type, vermin proof, mildew proof, fire retardant and non-hygroscopic.

5.2.2 Insulation shall be secured so as to prevent movement and to prevent retention of moisture leading to corrosion of surrounding materials.

5.3 Fastenings

5.3.1 All fasteners and other means of attachment used in the construction/modification of the ambulance/ERV shall be designed so as to provide a minimum restraining force of 10 times the weight of the component and/or object being secured.

5.3.2 All attachments shall be fastened in a manner that will preclude unintentional loosening.

5.3.3 Cabinets, benches, partitions, and rails shall be securely attached to metal tapping plates and/or framing welded to the body structure.

5.4 Plywood

All plywood shall be industry standard solid core with no voids for structural elements with waterproof glue construction.

5.5 Interior Finishes

5.5.1 The finish of all interior surfaces, other than OEM, shall be impervious to soap and water, disinfectants and mildew.

5.5.2 All surfaces, edges, corners and joints that can be exposed to any fluid shall be sealed by a waterproof bonding material.

6. EXTERIOR IDENTIFICATION

6.1 Objective

6.1.1 The exterior colour and markings shall readily identify the vehicle as an ambulance to all observers. This identification, in conjunction with the activated emergency warning systems, shall prompt the need to yield the right of way in the public's mind.

6.1.2 The design shall promote the safety of the occupants of the ambulance and other motorists or bystanders by enhancing the visibility of the ambulance.

6.1.3 As the effectiveness of individual colours and materials used in the exterior identification package may vary in different lighting levels the operator shall ensure that the total effect is balanced in order to achieve the maximum conspicuity over a 24-hour operation.

6.2 Identification Signage

6.2.1 Each ambulance shall display reflective signage stating "AMBULANCE" on sides, front (mirror image) and rear, with a contrasting reflective background behind the word "AMBULANCE" on sides and rear.

6.2.2 For the sides and rear, the "Ambulance" legend shall be approximately 180 mm high and proportional in width with bold font lettering, in a prominent colour.

6.2.3 The "AMBULANCE" reverse legend shall be approximately 130 mm high and proportional in width with bold font lettering in a prominent contrasting colour to the background.

6.2.4 Additional signage may be applied provided it does not infringe on the prominence of the "AMBULANCE" identification.

6.3 **Intentionally deleted**

7. CONSTRUCTION AND DESIGN DETAILS

7.1 Safety by Design

7.1.1 The ambulance shall be designed and constructed to maximise the safety and security of the occupants.

- 7.1.2 To the greatest extent possible, the interior walls and ceiling of the ambulance shall present a simple plane surface. This requirement applies in particular to the surfaces (cabinet fronts, doors, windows, cushion, etc.) that make up the front wall of the patient compartment.
- 7.1.3 The interior of the patient and driver compartments shall be free of all sharp projections.
- 7.1.4 All hangers or supports for equipment, lighting, controls and other devices shall be mounted as flush as possible with the surrounding surface.
- 7.1.5 Padding (bolsters) shall be placed at all head areas and obstructions that may prove dangerous to persons moving about in the ambulance.
- 7.1.6 All exposed edges and corners, neither padded nor protected by "T" moulding, shall be broken with the largest possible radius or chamfer, at minimum a 3 mm chamfer or a 15 mm radius.
- 7.1.7 The interior of the patient compartment shall be designed and constructed to minimize containment areas for the incubation of viruses either air borne or transmitted in fluids.
- 7.1.8 All stepping surfaces (i.e. front cab and patient compartment step wells) shall be covered with heavy-duty ribbed rubber matting or other anti-skid material for skid protection.
- 7.1.9 All securing straps, cargo nets and other restraints shall be capable of retaining 10 times the total weight of the equipment or material they are designed to contain.
- 7.1.10 Doors, hatches and covers shall be designed to contain 10 times the weight of the items stored loose behind the door, hatch or cover.

7.1.11 Equipment installed in the cab shall be located and mounted in such a way that it shall not interfere with the operation of the driver side and/or passenger side air bag(s) if the vehicle is so equipped.

7.1.12 **Intentionally deleted**

7.2 General Construction Methods

7.2.1 **Panels shall be installed in a manner that prevents sagging, deflection, warping or vibration.**

7.2.2 **Intentionally deleted**

7.3 **Intentionally deleted**

7.4 Cab Headliner

If a cab headliner other than the OEM supplied headliner is installed, then the resulting headroom clearance shall not be lower than that of the original OEM cab headliner.

7.5 Patient Compartment Flooring

7.5.1 Floor shall be at the lowest level permitted by the chassis/body not to exceed limits expressed elsewhere in this *Standard*.

7.5.2 All floor areas shall withstand a distributed load of 735 kg/sq m. Floors shall be reinforced to eliminate "oil canning".

7.5.3 The floor covering shall be fireproof no wax type, mark resistant and scuff proof safety flooring. It shall provide a static friction coefficient equal to or greater than 0.8 under dry conditions and be warranted by the flooring manufacturer to maintain that factor for at least seven (7) years in use in an ambulance.

7.5.4 All floor level mouldings, edging and trim shall be sealed to prevent fluids from seeping under cabinets, walls, etc.

7.6 Bulkhead Partition

7.6.1 A full height and width bulkhead partition shall be placed between the driver and patient compartments. This partition shall be located behind the driver and passenger seats. The partition shall be secured by welding or bolting to tapping plates.

7.6.2 A communication window shall be placed in the bulkhead. Its position shall be such that the driver may view the patient compartment by means of the interior rear view mirror.

7.6.3 In the construction of the bulkhead, the seat travel of both the driver and passenger's seats shall not be reduced from that provided by the OEM.

7.6.4 For a Type 1 ambulance, the communicating window shall be in the front wall of the ambulance body and accessible to the cab.

7.7 Patient Compartment Reinforcing Bar

In Type 2 ambulances, a mild steel reinforcing bar minimum 100 mm wide and 5 mm thick, or equivalent, shall run around the total perimeter of the patient compartment including the doors. This bar is to be welded to body ribs, bulk head reinforcement, door posts, and framework of doors.

7.8 Patient Compartment Side Door Step

7.8.1 The side entrance to the patient compartment shall provide ease of access for an ambulatory patient. This shall include stepping surfaces that are minimum 200 mm wide (from edge to riser) and no more than 560 mm above the ground.

7.8.2 Where a permanently fixed exterior step has been installed it shall be capable of supporting a test weight of 225 kg.

7.8.3 For Type 2 ambulances, when allowed by OEM practices, the present patient compartment side entrance step-well may be widened as necessary to comply. Alternatively, a permanently fixed exterior step (running board) capable of supporting a test weight of 225 kg shall be provided.

7.9 Rear Step Bumper

7.9.1 The ambulance shall be equipped with a step bumper at the rear capable of supporting a test weight of 225 kg.

7.9.2 The safety grating step shall run the length of the rear door opening, be 240 mm wide and hinge or pivot to permit ambulance attendants to move closer for loading and unloading of cot.

7.9.3 The rear step bumper shall be positioned so that the stepping surface is approximately mid way between the ground and the finished floor of the ambulance. This location shall not reduce the angle of departure from that provided by an OEM step bumper as measured in accordance with SAE J689.

7.9.4 **Intentionally deleted**

7.9.5 When a power lift is installed to lift cots into the ambulance the rear step is exempt from hinge or pivoting requirement of 7.9.2.

7.10 Curb Clearance

7.10.1 Curb clearance, approach, departure and breakover angles shall meet or exceed the standards set out in SAE Recommended Practice J689.

7.10.2 **Intentionally deleted**

7.10.3 **Intentionally deleted**

8. HEATING, VENTILATION AND AIR CONDITIONING

- 8.1 The heating ventilation and air conditioning system (HVAC) shall maintain fresh air conditions and a comfortable temperature level in the patient compartment.
- 8.2 The HVAC system shall achieve all criteria and performance testing standards as detailed at Section 20.
- 8.3 The system shall be designed to operate using recirculated and/or ambient air
- 8.4 The system shall provide a positive pressure within the patient compartment.
- 8.5 The system provided in the patient compartment must be installed in a manner that allows for the independent control of the environment in this compartment from that in the driver compartment.
- 8.6 If modifications and/or additions are made to the OEM heater system, then the Contractor shall certify that the windshield defrosting and defogging system continue to comply with CMVSS #103.
- 8.7 The motors used to exhaust air for air exchange shall comply with C-UL requirements for spark protection (marine).
- 8.8 A thermostat system shall automatically control the heating and cooling functions so that the temperature in the patient compartment is constant within +/- 2°C.
- 8.9 Where supplied as part of the OEM chassis, the connection points provided by the auxiliary HVAC - connector package shall be used.

8.10 In chassis that do not provide an OEM connection point for the heater lines, heavy-duty unions shall be used where the heater hoses connect.

8.11 The total air conditioning system shall be connected and charged in accordance with the OEM manufacturer's specifications regarding gas, lubricant and pressure.

9. LOW VOLTAGE (12V DC) CONVERSION ELECTRICAL SYSTEM

9.1 General

9.1.1 The primary purpose of the ambulance is to move patients, trained personnel and patient care equipment between bases, the scene of incidents and hospitals. In order to do this, the battery(s) that is used to start the engine and operate OEM vehicle functions shall be protected from all other electrical demands.

9.1.2 The Contractor shall test each ambulance prior to delivery and provide the Purchaser with certification of compliance to the performance criteria in Section 20.

9.2 Electrical Load Isolation

Ambulance conversion electrical system loads shall be isolated from the OEM chassis battery(s). OEM chassis battery(s) shall only provide power for OEM chassis loads.

9.3 Conversion Battery

9.3.1 The ambulance conversion electrical system shall include a dedicated battery(s) (the conversion battery(s)) electrically separated from the OEM battery(s).

9.3.2 The conversion battery(s) shall be located in a ventilated area, sealed off from occupant compartments.

9.4 Uninterruptible Conversion Power Circuits

The following circuits shall be powered at all times: Incubator Receptacles, Two-Way Radio Power Supply, the Emergency Battery Boost System (if so equipped), and **a light in the patient's compartment.**

9.5 **Intentionally deleted**

9.6 Fuses and Circuit Breakers

All circuits shall be protected by means of properly sized fuses or circuit breakers.

9.7 Driver's Switch Panel

9.7.1 Switches to control the emergency warning lights, siren, scene lights and other ambulance functions shall be mounted in a switch panel located at the driver's console.

9.7.2 Design and location of console and switch placement should favour the driver as primary user but allow access to control functions from the passenger seat.

9.8 Patient Compartment Switch Panel

Switches to control the patient compartment lights, heating, air conditioning, and other patient compartment functions shall be mounted on the a switch panel at the attendant's control console at the action wall.

9.9 Door Activated Switches

9.9.1 Patient compartment side entrance door(s) shall be fitted with switch(es) which shall operate some interior patient compartment lights for general illumination when the door(s) is open.

9.9.2 Patient compartment rear entrance door(s) shall be fitted with switches that shall operate some interior patient compartment lights for general illumination and the rear scene lights for loading lights when the door(s) is open.

9.10 Door Ajar Light

A flashing red warning light shall be installed on the driver console to indicate when any of the patient compartment or the exterior storage doors is ajar.

9.11 Voltmeter

An illuminated voltmeter that monitors the condition of both the OEM and conversion battery(s) shall be provided. The gauge function shall be clearly labelled.

9.12 Two-Way Radio Power Supply

9.12.1 A terminal block shall be installed in the area provided for the mounting of radio equipment to accommodate the two-way radio power connections.

9.12.2 Two terminals are required on the Radio Terminal Block and labelled as POSITIVE and GROUND.

9.12.3 A pair of #4 gauge wires shall be provided, one shall be connected from the POSITIVE terminal of the block, in series with a 40 amp breaker (isolated from all other breakers), to the positive post of the conversion battery. The other from the GROUND to the metal frame of the chassis, separate from all other grounds, to ensure a good ground connection.

9.12.4 An insulated cover or terminal protectors shall be provided for the radio block to prevent accidental contact with the terminals.

9.13 Patient Compartment Lighting

9.13.1 **Intentionally deleted**

9.13.2 The intensity of this illumination shall be as detailed in the performance criteria at Section 20.

9.13.3 **Intentionally deleted**

9.13.4 **Intentionally deleted**

9.14 Incubator Receptacles

9.14.1 Two (2) 12 volt polarised outlets shall be installed in ambulance. An outlet is to be located near the head end of the primary cot, but not in the action wall. Each outlet is to be powered at all times.

9.14.2 Each outlet is to be circuit protected to 20 amps.

9.14.3 Outlets to be **Cinch Jones Series 2400 (6 contacts)** Ohmeda flush mount receptacles part #208-0527-300. Connections shall be soldered to terminals; terminal #11 to negative (ground), terminal #12 to positive; terminals shall be covered to protect any metal contact from causing short circuits.

9.15 Cabinetry Lighting

9.15.1 Each interior storage cabinet shall have at least one cabinet light for interior illumination. A switch located in the attendant control panel shall control lights.

9.15.2 All exterior compartments shall be provided with lighting and have two (2) function door switches to activate lights.

9.16 **Intentionally deleted**

9.17 **Intentionally deleted**

9.18 Relays

Any device subject to a load of 25 amps or greater shall be remotely switched by relays.

9.19 Electrical Load Rating

All wiring, electrical devices, switches, outlets, etc., except circuit breakers and fuses, shall be rated to carry at least 125 percent of the maximum ampere load for which the circuit is protected.

9.20 Wiring

9.20.1 All wiring shall be copper, with CSA/C-UL approved insulation.

9.20.2 Wiring must not pass across the floor of the driver compartment, nor under the floor mats or metal trim strips unless protected within a solid channel made of corrosion resistant material.

9.20.3 No wiring shall pass within 200 mm of the oxygen connectors or fittings.

9.21 **Intentionally deleted**

9.22 Backup Warning Alarm

9.22.1 To warn bystanders when the vehicle is backing up, a heavy duty reverse warning signal shall be installed to operate when the gear selector is in "REVERSE".

9.22.2 **For silent backing, a disable switch may be installed; however, this switch must be programmed to reset automatically prior to the lapse of 60 seconds from the time the switch is disabled.**

10. EMERGENCY WARNING SYSTEM

10.1 Design Parameters

10.1.1 The emergency warning system must provide the vehicle with all round conspicuity, be highly perceptible and have attention getting audio and visual signals for the safety of the ambulance and public.

10.1.2 The emergency lighting system shall utilise flashing lights and/or rotating beacons.

- 10.1.3 The emergency lighting system design shall follow the principle that:
- (1) white (clear) light will be used to gain the viewer's attention, red light will convey the "emergency" message, and amber light will convey the "caution" message;
 - (2) no colour other than red, white and amber shall be used;
 - (3) any flashing lights of the same light type (e.g. incandescent, halogen strobe or Neobe®) shall flash all lamps of the same colour together then alternate to the other colour along the same side and plane; and
 - (4) the exemptions to 10.1.3 (3) are:
 - (i) the white grille lights, these lights are not required to flash in or with any other lights on the vehicle,
 - (ii) when so equipped, traffic directional devices (sub-section 10.10) and
 - (iii) red or amber stop turn signalling devices required under the Highway Traffic Act of Ontario; and
 - (5) amber light(s) shall not flash at the same time as other emergency lights facing in the same direction.

The system shall be comprised of components and devices that comply with requirements of SAE J575, J576, J578, J591, J595, J1318 and J1889 as applicable to the unit.

- 10.1.4 The Primary Emergency Lighting system shall achieve all criteria and performance testing standards as detailed at Section 20.
- 10.1.5 The Primary Emergency Lighting system shall be wired to operate independently of the other warning lights and controlled by a separate switch on the driver's console.

10.2 Forward Roof Warning Lights

- 10.2.1 There shall be an array of red and white flashing or rotating lights installed on the forward vertical plane of the raised roof or the modular ambulance body. This array shall include two (2) red and one (1) white light. The white light shall be located toward the vehicle centreline.

10.2.2 The roof level forward warning lights shall be operated as part of the primary flash pattern. They may also be operated as a separate system by means of a switch at the driver's console.

10.3 Side and Rear Roof Level Warning Lights

10.3.1 There shall be an array of red and white flashing or rotating lights visible at the forward and rear, upper corners of each side of the modular ambulance body or raised roof. White to the centre.

10.3.2 There shall be an array of red and white flashing or rotating lights visible at the left and right, upper corners of the rear of the modular ambulance body or raised roof. White to the centre.

10.4 Scene Lights

10.4.1 Five (5) white (clear) scene lights, of 800 beam candle power minimum, shall be installed on the vertical plane of the outer roof skin (one spotlight located forward each side, one floodlight located to the rear each side and one floodlight on the rear). The floodlights shall be angled downward 12 to 15 degrees by means of mounting or lens and installed with minimum protrusion beyond the outer skin of the body.

10.4.2 Switches at the driver control console shall control the left, right and rear facing scene lights. This mode of control will take precedence over other modes described below.

10.4.3 At least one adjacent floodlight shall illuminate automatically when the rear doors of the patient compartment are opened.

10.4.4 The rear facing scene light(s) shall also operate automatically when the vehicle transmission is placed in reverse.

10.4.5 The scene lights may be used to fulfil the requirement for white lights in the Side and Rear Roof Level Warning Lights. In this case, they would be wired to flash as part of the primary emergency warning system.

10.5 Grille Lights

10.5.1 Red and white warning lights shall be installed on the vertical plane of the grille such that:

- (1) the location is in compliance with OEM considerations regarding air flow through the grille; and
- (2) the lights are visible in the rear view mirror(s) of a standard passenger car preceding the ambulance.

10.5.2 The red grille lights shall consist of two (2) flashing lights or a single rotating or oscillating beacon and shall be wired to operate with the primary flash pattern.

10.5.3 The white grille lights shall consist of two (2) lights (which may be the high beam of the OEM headlights when permitted by the OEM) which flash in an alternating or random sequence. These lights are exempt from meeting the requirements in paragraph 10.1.3(3). Alternatively, the white grille light may be a single rotating or oscillating beacon. The white grille light(s) shall be wired to operate independently of the other warning lights and controlled by a separate switch on the driver's console.

10.6 Intersection Lights

10.6.1 Red and a white intersection lights shall be installed at each of the front fenders.

10.6.2 The red and white lights shall be wired to flash, rotate or oscillate with the primary flash pattern.

10.7 Flash Patterns

The primary flash pattern shall include:

- (1) red and white Forward Roof Warning Lights;
- (2) red and white Side Roof Level Warning Lights;
- (3) red and white (not amber) Rear Roof Level Warning Lights;
- (4) the red Grille Lights; and
- (5) red and white Intersection Lights.

10.8 Siren - Public Address System

- 10.8.1 A combination siren and public address system, capable of producing high/low horn tones and other warning sounds complete with microphone and two speakers, shall be installed.
- 10.8.2 The siren shall be capable of amplifying the two-way radio audio but be independent of the radio system.
- 10.8.3 The siren will have remote control capability and be able to be activated by the vehicle horn ring when the siren/horn switch is on.
- 10.8.4 The siren control head shall be mounted on the driver control console and a securing clip shall be provided for the microphone also on the console.
- 10.8.5 The speakers shall be mounted at the forward vertical plane of the vehicle at the grille or on the bumper or below the bumper.
- 10.8.6 The mounting may incorporate the speakers and the grille lights in a Forward Warning Device.
- 10.8.7 The siren system shall meet the performance testing *Standard* as detailed in section 20.

10.9 **Intentionally deleted**

10.10 Traffic Directional Devices

When installed traffic directional devices may operate independently of the requirements of the design parameters described in sub-section 10.1.3(3).

11. 2-WAY RADIO INSTALLATIONS

11.1 General

11.1.1 The ambulance design shall provide for the installation of radio equipment.

11.1.2 The term "radio equipment" shall include all peripheral equipment associated with the radio, including:

- (1) **mobile radio unit which consists of the mobile radio transceiver and when provided, the mobile radio repeater package VHF/ UHF mobile repeater pkg;**
- (2) **front control head, microphone and speaker;** front control head;
- (3) **all associated antennas (the number will depend on the mobile radio unit, typically 2 antennas with the radio repeater);** rear control unit and handset;
- (4) **cables between the control head, speaker, mobile radio unit, battery and antenna;**
- (5) **rear/remote speaker and handset.** two all associated (2) speakers;

11.2 Radio Equipment Mounting

11.2.1 The ambulance shall have a compartment for mounting radio equipment which:

- (1) provides adequate access for installation or removal and periodic maintenance;
- (2) provides protection from physical damage; and
- (3) is ventilated.

- 11.2.2 A mounting position shall be provided for the radio control head and microphone clip in the cab that allows equal access for either the driver or passenger.
- 11.2.3 Space shall be provided to mount two remote speakers. One location to be in the cab between the driver and passenger, and one location to be near the rear facing attendant seat.
- 11.2.4 A mounting space shall be provided for the remote handset located at the action wall accessible from the attendant seat.
- 11.2.5 The mounting of radio equipment shall not interfere with other control functions or block vents, or block the line of sight for gauges or instruments or interfere with air bag type passenger restraint systems.
- 11.3 Antennae Access
- 11.3.1 Access shall be provided to enable the installation and maintenance of antennae and antenna cables without having to remove the headliners or cabinets.
- 11.3.2 Openings to pass antenna cables through walls etc. shall be minimum 25 mm diameter and protected by rubber or plastic grommets where it goes through metal or other abrasive areas.
- 11.4 Antenna Ground Plane
- 11.4.1 In vehicles equipped with a non-metallic roof, an antenna ground plane, minimum of 1m wide x 2 m long, shall be moulded into the roof.
- 11.4.2 The ground plane shall be grounded to the vehicle frame.
- 11.4.3 To enable installation of an antenna mount, the total thickness of the roof and ground plane shall not exceed 10 mm for a 75 mm diameter circle at each mount point.

11.4.4 At each antenna mount point, the lower surface of the ground plane shall be exposed to enable contact with the antenna mount.

11.5 Cable Routing

11.5.1 A means shall be provided **to protect** to run cables between the radio compartment and the radio control head, the remote speakers and the remote handset **from wear and damage**. This may include passages between sections of cabinetry and/or fixed conduits (with minimum inside dimension 75x50 mm) and/or removable channels (with minimum inside dimension 60x35 mm).

11.5.2 Maximum cable routing length between radio control head and radio compartment shall not exceed 17ft.

11.6 Installation of Radio Equipment

11.6.1 All radio equipment shall be installed so that all fasteners and other means of attachment used in the installation/relocation into the ambulance shall be designed so as to provide a minimum restraining force of 10 times the weight of the component and/or object being secured.

11.6.2 All attachments shall be fastened in a manner that will preclude unintentional loosening.

11.6.3 Mounting of radio equipment shall not interfere with other control functions, block vents or instruments or interfere with air bag passenger restraint systems.

11.6.4 Documentation confirming installation compliance with this section shall be kept on file by the operator for inspection by the Ministry.

12. OXYGEN SYSTEM

12.1 General

12.1.1 The ambulance shall have a hospital type oxygen system capable of storing and supplying medical oxygen as specified by the PES. It shall comply with all requirements for distribution and the performance criteria at Section 20.

12.1.2 Threaded fittings shall all be gas specific (CSA) and cleaned for oxygen service.

12.1.3 Devices shall be colour coded to indicate oxygen.

12.1.4 All apparatus shall be permanently identified with the manufacturer's name, calibrated conditions and specific markings including warning/caution information.

12.1.5 The oxygen lines running between the storage tank regulator and the wall outlets shall be low pressure hose assemblies.

12.2 Oxygen Outlet(s)

12.2.1 Oxygen outlets shall be compatible with oxygen delivery equipment specified by the PES.

12.2.2 **Intentionally deleted**

12.2.3 Oxygen outlets are to be located so that they do not pose a hazard to the patient (on the cot with the head of the cot reclined or in any elevated position) or to the attendant. Safe clearance shall include space for the flow meter, humidifier bottle, etc.

12.2.4 **Intentionally deleted**

12.3 Oxygen Cylinder Storage

Regardless of location all oxygen cylinder storage cradles must be designed and mounted to comply with all criteria for oxygen tank retention (Section 20).

13. SUCTION ASPIRATION SYSTEM

13.1 A complete electrically powered suction aspiration system shall be installed as specified by the PES.

13.2 **Intentionally Deleted**

13.3 **Intentionally Deleted**

13.4 **Intentionally Deleted**

13.5 The suction outlet and associated equipment is to be located so that it does not pose a hazard to the patient (on the cot with the head of the cot reclined or in any elevated position) or to the attendant.

14. ACCOMMODATION AND STORAGE

14.1 General

14.1.1 Each ambulance shall be designed with adequate accommodation for **a minimum of:**

- (1) one patient on a main cot; incubator or other mobile patient transporter; and
- (2) **seating for 1 Paramedic and 1 other passenger in patient compartment in addition to the patient;** and
- (3) the driver and one other passenger in the cab.

14.1.2 Special purpose ambulances may have different accommodation configurations than as specified in sub-section 14.1.1 so long as any such different configuration has been approved by the Director.

14.1.3 Accommodation and storage arrangements for ambulances shall generally fall into three (3) categories:

- (1) Single Main Cot;
- (2) Dual Main Cot; and
- (3) Special Purpose.

14.1.4 **Intentionally Deleted**

14.1.5 **Intentionally Deleted**

14.1.6 The arrangement of the patient compartment of a special purpose ambulance shall be as approved by the Director.

14.2 Main Cot Mounting

14.2.1 **Intentionally deleted**

14.2.2 Main cot retention systems shall be tested in accordance with the performance criteria (Section 20).

14.2.3 Main cots shall be positioned so that there is a minimum of 150 mm clearance between the rearmost part of the cot and the nearest obstruction.

14.2.4 **Intentionally deleted**

14.2.5 Each cot and stretcher shall be able to be removed, independent of each other, through the rear and the side doors with a patient in place.

14.3 Action Wall

14.3.1 **Intentionally Deleted**

14.3.2 The action area shall provide a work surface for the attendant seated in the **primary** attendant seat. It shall incorporate the main oxygen outlet and controls; the suction outlet and controls; the attendant control console (patient compartment switch panel); thermostat for HVAC system(s); reading light; and mounting space for the two-way radio handset and speaker **and be readily accessible to primary attendant seat**

14.3.3 The action wall shall be accessible to the **primary** attendant seating position.

14.3.4 **Intentionally Deleted**

14.3.5 Switches at the action wall shall be recessed or otherwise protected from accidental operation as by the attendant's knee or by material being placed on the work surface.

14.4 **Intentionally Deleted**

14.5 **Optional Squad Bench (Single Main Cot Ambulance)**

14.5.1 When provided it shall provide storage space in the interior and seating for passenger(s).

14.5.2 The squad bench lid shall be fitted with hinge(s) and a latch(es) to hold it in the closed position. It shall be supported in the open position by a hold open device.

14.5.3 Seating positions for ~~three~~ passengers on the squad bench will be provided by means of seat, back and headrest cushions.

14.5.4 **Seat** belts shall be installed **at all designated seating positions and shall meet the requirements in section 20** at the squad bench to accommodate persons sitting on the bench.

14.6 **Optional folding stretcher mounting**

- 14.6.1** **The stretcher is to be secured into place by either a mechanical device or two (2) non-retracting type seat belt sets will be provided to secure a patient on a folding stretcher to the squad bench. These belts will be long enough to pass over the patient and the stretcher. This may be accomplished by using the seat belts provided above with two (2) additional sections of belt anchored inside the bench.**
- 14.6.2** Recesses that fit the posts and/or wheels of the folding stretcher shall be installed to assist in securing the stretcher.
- 14.6.3** The folding stretcher shall be accommodated such that the head of the stretcher may be set in any position from the horizontal up to a 45° angle.

14.7 Squad Seat (Dual Main Cot Ambulance)

14.7.1 In a dual main cot ambulance, a flip-up type squad seat that will fold down immediately over the right hand main cot and be capable of seating **passenger(s)** shall be installed.

14.7.2 The squad seat shall be equipped with a positive device to retain it in either the raised or lowered position.

14.7.3 Seating positions for passenger(s) on the squad seat will be provided by means of permanently installed seat, back and headrest cushions.

14.7.4 Seat belts shall be installed for the squad seat to accommodate persons sitting on the seat.

14.7.5 Neither the squad seat nor head/back rests shall protrude out of the wall so as to hinder the use or elevation of the head end of the right hand cot.

14.7.6 The height of the squad seat above the floor shall be the minimum required to accommodate the cot, complete with mattress and linen, below the lowered seat.

14.8 Auxiliary Seating (Dual Main Cot Ambulance)

14.8.1 In a dual main cot ambulance, a rear facing seat shall be securely mounted at the front right of the patient compartment to enable the occupant to observe a patient on the second cot.

14.8.2 The auxiliary seat shall be equipped with permanently mounted seat, back and headrest cushions.

14.8.3 A seat belt shall be provided.

14.9 Storage Requirements and Design

14.9.1 Each Ambulance shall be designed with adequate storage for all **minimum mandatory** equipment as specified by the PES.

- 14.9.2 Storage cabinets shall be easily opened, but shall not come open in transit or as the result of a vehicle collision.
- 14.9.3 Doors, hatches and covers shall be designed to contain 10 times the total weight of the items stored loose behind the door, hatch or cover. The maximum to be secured shall be clearly labelled.
- 14.9.4 Open shelves or compartments shall be provided with easily removable belts or cargo nets designed to contain 10 times the total weight of the items stored loose on the shelf or in the compartment. The maximum weight to be secured in an area shall be clearly labelled.
- 14.9.5 **Intentionally deleted**
- 14.9.6 All glazing in cabinet doors etc. must bear a permanent identifying mark certifying compliance with current Transport Canada Regulations for motor vehicle glazing.
- 14.10 **Optional Intravenous Holders**
IV hooks **must have**with securing straps for IV solutions.
- 14.11 **Waste Receptacles**
Individual receptacles shall be provided for trash, hazardous waste and sharps.
- 14.12 **Intentionally Deleted**
- 14.13 **Spare Tire Storage**
Where a spare tire is to be carried internally, a storage area shall be provided of sufficient size to accommodate the winter tread model of the certified tire for the vehicle. The tire tools and jack shall be securely fastened within a compartment.

14.14 Incubator Rear Tie-down

Fixtures to secure the rear tie-downs for incubators are to be mounted at the rear door threshold in a manner that minimises the potential tripping hazard.

15. SAFETY EQUIPMENT

15.1 General

All equipment and accessories installed are to be designed and affixed so as to maximise the safety and security of the attendants, patients and passengers.

15.2 Bolsters

15.2.1 Bolsters (padded cushions) shall be provided at all openings and projections and obstructions which may prove dangerous to persons moving about inside the ambulance or seated within the ambulance or entering and leaving the ambulance.

15.2.2 At minimum, bolsters will be installed as follows:

- (1) bolsters across the full width of the interior top sill of each door opening in the patient compartment;
- (2) head bolsters adjacent to each seating position;
- (3) two head bolsters installed on the divider wall immediately above and behind the driver and passenger seats; and
- (4) bolsters to protect the elbow, shoulder and head of an attendant in the rear facing attendant seat next to the action wall.

15.2.3 Where bolsters are used for protection at right angled corners, the structure behind the padding (e.g. corner of a cabinet and backing of the bolster) shall have a radius to the largest reasonable dimension.

15.3 Grab Handles/Grab Rails

15.3.1 Every ambulance shall have grab handles and grab rails installed where necessary to assist persons moving about in the ambulance or seated in the ambulance or entering and leaving the ambulance.

15.3.2 **Intentionally deleted**

15.3.3 **Intentionally deleted**

15.3.4 **Intentionally deleted**

15.3.5 **Intentionally deleted**

15.3.6 **Intentionally deleted**

15.3.7 Installation of grab rails and handles shall comply with criteria at Section 20.

15.4 Reflective Safety Strips

Reflective safety stripe or reflective lenses shall be installed on the outer edge of all exterior doors to enhance visibility of these doors when open.

15.5 Convex Mirrors

Convex rear view mirrors, minimum 125 mm in diameter, shall be attached to the vehicle's OEM right and left hand mirror brackets by means of separate brackets. OEM or aftermarket combination mirrors providing the convex feature are an acceptable alternative.

15.6 Fire Extinguishers

15.6.1 Two (2) fire extinguishers, **5lb; C-UL approved; rating 3-A, 10 BC; rechargeable type with pressure gauge & service inspection tag** shall be **supplied and** installed.

- 15.6.2 Regardless of location all extinguishers are to be secured by a quick release bracket or in a container that complies with the retention criteria given in Section 20.
- 15.6.3 Extinguishers are to be located one in the cab and one in the patient compartment. Preferred locations are adjacent to doors.
- 15.7 Passenger Restraint
- 15.7.1 All seating positions shall be provided with seat belts and shall comply with CMVSS. Where there is no regulation under CMVSS the installation shall use materials and design which meets the spirit of CMVSS regulations for passenger restraint. Installations shall be tested to CMVSS standards.
- 15.7.2 The geometry of any seat belt arrangement shall provide pelvic restraint designed to remain on the pelvis of the occupant.
- 15.7.3 All side facing seats require a device such as a net or a vertical bolster located at the forward edge of the seat area. This device is intended to prevent the occupant(s) of the seat from moving forward during rapid deceleration. This device shall restrain the occupant(s) along the side of their body and head to prevent extensive flexing of the spine or neck. This device shall meet the requirements in section 20.

16. INTERIOR SIGNS AND LABELS

16.1 General

- 16.1.1 Any signage that may be necessary to convey operating or occupational health and safety instructions to attendants and/or occupants of the ambulance as the result of the chassis design, conversion design or equipment installations shall be installed.

16.1.2 **Intentionally deleted**

16.2 Doors

Appropriate signs shall be fixed to the inside of the patient compartment doors (side and rear) stating: "**OPEN THIS DOOR FIRST**", and "**TO OPEN PULL HANDLE INWARD**", or similar wording to suit the actual inside latch mechanism.

16.3 Outlets

Appropriate decals shall be fixed to denote incubator plugs, accessory receptacles and other electrical outlets.

16.4 **Intentionally deleted**

16.5 Controls

16.5.1 Appropriate signage shall identify the following:

- (1) Conversion switches and indicators (Driver Compartment);
- (2) Conversion switches (Patient Compartment); and
- (3) Temperature controls (Patient Compartment).

16.5.2 All switches, indicators and control devices supplied by the Contractor shall be permanently identified with signage clearly visible to the ambulance attendants and either illuminated or etched on back lit panels.

16.6 Vehicle Height Indication

The overall height of the vehicle shall be posted so as to be easily seen from the driver's seat. The label shall indicate the height both in metres and feet and include an allowance of 250 mm (10 inches) for the roof mounted antenna.

16.7 Weight Decal
An appropriate decal shall be affixed in clear view of the driver that indicates the payload, maximum number of occupants and cargo carrying capacity (C.C.C.) for the vehicle as detailed in sub-section 18.3.3

16.8 Pressure Vessel Decal
Each holder shall be labelled with the type and size of tank(s) it is to restrain.

17. MODULAR AMBULANCE BODY- TYPE 1 AND TYPE 3

17.1 General

17.1.1 The modular ambulance body shall comply with the Ambulance Performance Standards described in Section 20.

17.1.2 **Intentionally deleted**

17.2 Body Mounting

17.2.1 The body shall be mounted to the chassis with high strength fasteners and vibration isolating rubber body mounts designed and installed in accordance with the chassis manufacturer's guidelines.

17.2.2 Modular bodies shall not be welded to the frame at any point.

17.3 Doors

17.3.1 Door openings to the patient compartment shall be provided at the rear of the body and on the curbside ahead of the right rear wheel.

17.3.2 Each door shall have suitable hold open devices for the type and size of door and door stops to prevent damage to body sides.

17.3.3 **Intentionally deleted**

17.3.4 The rear door(s) shall provide a minimum clear opening of 1120 mm x 1270 mm. Dual rear doors with vertical hinges shall open to a minimum door angle of 150 degrees.

17.3.5 The curbside door opening shall be of sufficient size to accommodate the emergency removal of patients on both cots.

17.4 Windows

17.4.1 **Intentionally deleted**

17.4.2 Fixed windows shall be mounted in the rear doors.

17.4.3 **Intentionally deleted**

17.5 Door Latches

17.5.1 Door latches shall be automotive style, Transport Canada approved, with a two (2) stage catch mechanism.

17.5.2 Locks and release handles for the patient compartment doors shall allow the doors to be locked or unlocked from inside the patient compartment without using a key.

17.6 Electrical Ground

Electrical ground straps or cables between the body and chassis frame shall be installed as required by the OEM and sound engineering practices.

18. AMBULANCE CHASSIS SPECIFICATION

18.1 General

Only chassis approved by the OEM shall be used for an ambulance.

18.2 Intentionally Deleted**18.3 Payload Allowance**

18.3.1 Each unit shall have a minimum of 770 kg (1700 lbs) over and above the converted curb weight of unit as measured per sub-section 20.6.3.3.

18.3.2 Each unit shall display in clear view of the driver a decal indicating at minimum;

- (1) Payload, in kilograms and pounds
- (2) Maximum number of occupants
- (3) Cargo Carrying Capacity (C.C.C) in kilograms and pounds

I.e Payload = 886 kg/1950 lbs

Max. Occupants = 7 @ 91 kg/200 lbs each

C.C.C. = 250 kg/550 lbs

18.3.3 The total weight of the occupants and cargo shall not exceed the payload

18.4 Electronic Equipment Interference

Any component of the vehicle that is susceptible to interference from ambulance radio frequencies or to interference from any other added electronic equipment shall be shielded and/or protected from that interference.

19. CERTIFICATION OF AN AMBULANCE MODEL**19.1 General**

19.1.1 Every new and remounted ambulance model of ambulances intended to be used in the Province shall be certified by the Director before such ambulances are placed in service. Certification shall be in full compliance with this *Standard*.

- 19.1.2 Nothing in this sub-section prevents the Director from certifying individual ambulances before such ambulances are placed in service. In such a case, certification shall be granted only where the ambulance in question is in full compliance with this *Standard*.
- 19.1.3 The Contractor shall apply for certification of an ambulance model by submitting the following documentation:
- (1) a letter signed by the Contractor stating that the ambulance model as offered for use in the Province of Ontario is in compliance with all provisions of this *Standard*;
 - (2) a copy of all test certificates and technical reports required for the Performance Standards (Section 20);
 - (3) a copy of the Owner's Manual required under Section 4;
 - (4) a copy of the "Ministerial Authorization" for the use of the National Safety Mark issued by Transport Canada relevant to the ambulance model for Canadian Contractors. Models proposed by American Contractors shall be included in the current edition of the Transport Canada 'List of Vehicles Admissible from the United States';
 - (5) an electrical schematic drawing which clearly explains how the isolation of loads required under Section 9 has been accomplished.
 - (6) a completed copy of Annex C (New Ambulance) or Annex D (Remounted Ambulance) noting compliance with specified sections of the *Standard*, signed by an officer of the Contractor, dated and notarised; and
 - (7) included with the test submission shall be model or part numbers of products tested and a pictorial record of the tests.
 - (8) a copy of the approval from the OEM for the use of the chassis for an ambulance conversion.
- 19.1.4 Ambulance model certification will be granted solely at the discretion of the Director and shall be in writing.

- 19.1.5 Ambulance model certification and individual test certificates shall remain valid for a maximum of three (3) years so long as they are applicable to the vehicle model, component(s) and equipment offered as tested under this *Standard*. After the expiry of the three (3) year period, and subject to sub-section 19.1.6, the ambulance model then shall require recertification. The date that the oldest test was completed, as submitted under sub-section 19.1.3 (2), will form the basis for determination of the start date for the three (3) year term of certification.
- 19.1.6 In lieu of recertification, a Contractor may make application to the Director of the Emergency Health Services Branch to have the term of an ambulance model certification or of an individual test certificate extended for an additional period of one year. Such application must include a detailed argument, based on sound engineering principles, explaining why the extension should be granted. Extensions will be granted solely at the discretion of the Director and shall be in writing. A maximum of two extensions, of one year each, will be allowed for any individual certification.
- 19.1.7 Each ambulance purchased by the Ministry of Health and Long-Term Care, Emergency Health Services Branch or the former Municipality of Metropolitan Toronto on or before December 31, 1997 and in service from December 31, 1997, to the present, shall be deemed to be certified. However, this *Standard* shall otherwise fully apply in respect of each ambulance, allowing for all necessary modifications.
- 19.1.8 Each ambulance certified for use in Ontario under previous versions of the *Standard* shall be deemed to continue to be certified under the current version until sold, or remounted, refurbished, or modified in any fashion which contravenes the version in effect at the time of change.
- 19.2 Certificates and Reports
- 19.2.1 The Contractor shall retain on file the original copy of all currently valid test certificates required under the Performance Standards (Section 20) and complete technical reports in support of those certificates.

- 19.2.2 Each individual test certificate shall clearly state:
- (1) the number and title and date of revision of the Performance Standard;
 - (2) the date and location when the test was performed;
 - (3) the name of the company or organisation which completed the test;
 - (4) the name and title of the person who has verified the test results complete with signature (and proof of registration for an engineer);
 - (5) that the test requirements were passed;
 - (6) the chassis type(s) and ambulance type(s) for which the certificate is valid;
 - (7) the make, model, year and Vehicle Identification Number of the tested chassis;
 - (8) the make, model, type and year of the tested ambulance conversion;
 - (9) the make, model, and other identifying marks on any components being tested or that make up systems which are being tested; and
 - (10) the make, model, and other identifying marks on any components being tested or that make up systems which are being tested and include photographs and/or diagrams that clearly distinguish the components or systems for future reference.
- 19.2.3 Each technical report held in support of a test certificate shall contain at minimum:
- (1) all information required on the test certificate;
 - (2) all data collected in performance of the test including any descriptive or explanatory notes; and
 - (3) a description of equipment and facilities used to perform the tests (including date last calibrated as applicable).
 - (4) next calibration due date.
- 19.2.4 The following tests shall be completed by a Registered Professional Engineer and certified as conforming to these Performance Standards.
- (1) Main Cot Retention;
 - (2) Static Load Test For Ambulance Body Structures;
 - (3) HVAC Performance Tests;
 - (4) Pressure Vessel Retention;

- (5) Interior Sound Level Test;
- (6) Centre of Gravity Location;
- (7) Interior Lighting Test;
- (8) Body Door Components Test;
- (9) Emergency Lighting Requirements;
- (10) Carbon Monoxide Levels;
- (11) Load Test for Grab Rail/Handles;
- (12) Siren/Public Address System Sound Levels;
- (13) Incubator Restraint Load Test; and
- (14) Passenger and Patient Safety Restraints Load Tests.
- (15) 10G Restraint Test
- (16) Occupant Restraint Load Test

19.2.5 The following tests shall be completed by the Contractor and certified as conforming to these Performance Standards.

- (1) Vehicle Weight Distribution;
- (2) 12 Volt dc Electrical System Performance;
- (3) Electromagnetic Radiation and Suppression Test;
- (4) Antenna System Test;
- (5) Oxygen System Pressure Test; .
- (6) Occupant Head Protection Zone

19.2.6 Certification from the OEM chassis manufacturer and individual equipment manufacturers are acceptable providing they are not part of a system(s) or altered and are in accordance with sub-section 19.2.2.

19.2.7 Testing results of single components produced by the OEM chassis manufacturer and individual equipment manufacturers are acceptable provided that the component tested is not incorporated or utilized as part of a larger system or entity or altered in any way, and that the results are in accordance with sub-section 19.2.2.

19.3 Certificate Distribution

19.3.1 The Contractor, at time of delivery, shall provide a copy of the ambulance model certification signed by the Director of the Emergency Health Services Branch with each ambulance sold for use in Ontario.

19.3.2 A completed Compliance Checklist (Annex C or Annex D as appropriate), for the individual ambulance being sold, shall be included with the ambulance model certification.

19.3.3 Where the Purchaser is other than the Ministry, the name of the Purchaser, shall also be included in Part IV of the Checklist.

19.4 Non-Compliant Vehicles

19.4.1 When the Contractor provides a non-compliant ambulance at the request of the Purchaser, the supplied copy of the ambulance model certification shall be annotated as “Non-Compliant Vehicle– See Attached”.

19.4.2 The attached Compliance Checklist shall provide specifics of the areas of non-compliance in Part II.

19.4.3 A copy of the documentation described above shall be immediately forwarded by the contractor to the Ministry prior to the delivery of the ambulance.

19.4.4 With respect to the non-compliant ambulance, the operator shall ensure that the areas of non-compliance are rectified and advise the Ministry, in writing, of the corrective action prior to the ambulance being placed in operation in Ontario. A copy of the ambulance model certification and compliance checklist referred to in sub-sections 19.4.1 and 19.4.2 will be forwarded with the written notification.

19.4.5 The operator shall retain on file all documentation and testing information, providing details related to the corrective action taken for review by the Ministry.

19.5 Continued Compliance

19.5.1 It shall be the responsibility of the operator to ensure that the ambulance continues to be in compliance with the applicable version of the *Standard*.

19.5.2 Any subsequent modifications or changes made shall be in accordance with the version of the *Standard* in effect at the time of the modification or change. Where modifications or changes occur to components or material that require testing under the Performance Standards, the operator shall ensure that new testing is undertaken and completed. The version of the *Standard* in effect at the time of change will be the applicable reference for testing.

19.5.3 The operator shall maintain on file all necessary documentation including confirmation of compliance and new testing information related to the modified or changed ambulance for inspection by the Ministry.

19.6 Compliance Review Program

19.6.1 The Ministry shall maintain a program to monitor the compliance by the Contractor with the requirements under this *Standard*.

19.6.2 The program shall include site visits to the Contractor's production facilities at times while manufacturing and/or performance standard testing of ambulances intended for use in Ontario is occurring or at such other reasonable times as determined by the Director. To aid in scheduling Ministry compliance reviews the Contractor shall regularly provide the Director with a minimum of 21 calendar days notice prior to commencing conversion or testing of ambulances being produced for use in Ontario.

19.6.3 The Contractor shall make available to designated Ministry personnel, for inspection and review, all documentation relating to the production and certification testing of ambulances being produced for use in Ontario.

19.6.4 Where the Contractor employs sub-contractors, testing agencies or consultants to provide goods or services, the process described in sub-sections 19.6.2 and 19.6.3 shall apply. The Contractor shall arrange access for Ministry personnel to the facilities of its sub-contractors, testing agencies or consultants to observe activities relating to the manufacturing and/or performance standard testing of ambulances intended for use in Ontario.

19.7 Revocation and Suspension of an Ambulance Certification

19.7.1 The Director may revoke or suspend an ambulance model certification:

- (1) where a revision to, or a new version of, the *Standard* requires new testing certification of any Performance Standards listed in sub-section 19.2.4 or 19.2.5;
- (2) where the Contractor fails to provide required notification, documentation and/or access to production and testing facilities as described in sub-section 19.6; or
- (3) where the Director is of the view that the Contractor has contravened any requirement under this *Standard*.

19.7.2 The Director may revoke or suspend an individual ambulance certification:

- (1) where a revision to, or a new version of, the *Standard* requires new testing certification of any Performance Standards listed in sub-section 19.2.4 or 19.2.5;
- (2) where the operator fails to provide required documentation and/or testing information and/or access to production and testing facilities as described in sub-section 19.5.3; or
- (3) where the Director is of the view that the operator has contravened any requirement under this *Standard*.

19.8 Fees

19.8.1 The Director may, from time to time, establish fee schedules relating to the recovery from the Contractor of travel expenses and any other costs associated with the provision of ambulance model certification and compliance monitoring.

20. AMBULANCE PERFORMANCE STANDARDS

20.1 Main Cot Retention

20.1.1 Scope:

This performance standard establishes requirements for the main cot retention systems as installed in single and dual main cot ambulances.

20.1.2 Requirements:

20.1.2.1 Each main cot retention system shall be capable of meeting requirements set forth under this performance standard when tested in accordance with test procedures as here in outlined.

20.1.2.2 The main cot retention system, anchorages and stretcher fastener(s) shall not fail or release when subjected to a force of 12,230 Newtons (N) applied in a horizontal plane in a longitudinal, lateral and vertical direction. (Note: these are three individual tests).

20.1.2.3 Testing shall be certified by a Registered Professional Engineer

20.1.3 Test Conditions:

20.1.3.1 The ambulance floor shall be in a horizontal plane.

20.1.3.2 If the ambulance is designed to transport multiple main cots, the main cot retention system shall be tested in each location. If adjustable, the main cot retention system shall be adjusted to its most forward position.

20.1.4 Test Procedure:

20.1.4.1 Apply the specified force through the hook(s) (or other cot securing means) used in locking onto the cot using the test device.

20.1.4.2 Install the test device in the main cot retention system in such a manner that will preclude contact friction with floor or other surfaces.

- 20.1.4.3 Apply an initial vertical upward load to the test device pivot.
- 20.1.4.4 As rapidly as possible, apply the fully specified force to the device.
- 20.1.4.5 Record the applied force, start and finish times and any deformation of the floor, cabinetry or retention mechanism.
- 20.1.4.6 Release applied load. If any deformation has occurred in the main cot retention system, replace damaged parts. Note: rotation or deformation of retention mechanism does not constitute failure.
- 20.1.4.7 Reinstall test fixture and repeat above steps in the longitudinal and again in the lateral direction. Record all resultant data.
- 20.1.5 Test Equipment:
The testing device is a structure of appropriate design to represent the attachment points of a main cot and is used for locking onto the hook(s) (or other cot securing means) of the main cot retention system. Force is applied through a pivot located 380 mm above the floor, at a point representing the centre of the cot.

20.2 Static Load Test for Ambulance Body Structures

- 20.2.1 Scope:
This performance standard establishes performance requirements for ambulance body structural integrity and is applicable to all ambulances where: a) modifications are made to OEM roofs, and/or; b) the body is manufactured by the Contractor.

20.2.2 Definitions:

"Converted Curb Weight" means the actual weight of the vehicle with all standard OEM equipment; carrying its maximum capacity of fuel, oil and coolant and including the weight of the conversion and all equipment as supplied by the Contractor in accordance with the terms of this Standard.

20.2.3 Requirements:

20.2.3.1 For Type II ambulances a force equal to 1.5 times the converted curb weight of the vehicle, and for Types I and III ambulances 2.5 times the converted curb weight of the vehicle is applied to the roof of the vehicle's body structure through a force application plate, the downward vertical movement at any point on the application plate shall not exceed 100 mm.

20.2.3.2 Each exterior exit door of the vehicle shall be capable of opening during the full application of the force and after release of the force. A particular vehicle, i.e., prototype need not meet the opening requirements after release of force if it is subject to opening requirements during the full application of force.

20.2.3.3 No structural or component damage, i.e., torn or broken material, broken welds, popped or sheared rivets, bolts and/or fasteners shall be evident during the application of the force and after the release of the force.

20.2.4 For Types I and III ambulances a force equal to 2.5 times the curb weight of the vehicle is applied to the left or right side of the body structure through a force application plate; the downward vertical movement at any point on the application plate shall not exceed 100 mm.

20.2.4.1 The rear exit doors of the vehicle shall be capable of opening during the full application of the force and after release of the force. The vehicle need not meet the opening requirements after release of force if it is subject to opening requirements during the full application of force.

- 20.2.4.2 No structural or component damage, e.g., torn or broken material, broken welds, popped or sheared rivets, bolts and/or fasteners shall be evident during the application of the force and after the release of the force.
- 20.2.4.3 Testing shall be certified by a Registered Professional Engineer
- 20.2.5 Test Procedure designed for 20.2.3:
- 20.2.5.1 Place the vehicle on a rigid horizontal surface so that the vehicle is entirely supported by means of the vehicle frame without any support from the suspension system. If the vehicle is constructed without a frame, place the vehicle on its body sill. Remove any components which extend upwards from the vehicle roof. A modular body may be tested off of the chassis it's intended for, in which case the following applies;
- (1) the module shall be placed on I beams to simulate the chassis frame
 - (2) Total weight applied shall still include 2.5 times the total curb weight of the finished ambulance.
- 20.2.5.2 Apply a rigid, rectangular force application plate fitted as near as possible to the contour of the ambulance roof.
- 20.2.5.3 Position the force application plate on the vehicle roof so that its rigid surface is perpendicular to a vertical longitudinal plane and so that in the top projected view, its longitudinal centreline coincides with the longitudinal centreline of the vehicle, and it is centred on the roof of the vehicle.
- 20.2.5.4 With all doors fully closed, apply an evenly distributed vertical force in the downward direction to the force application plate at any rate not more than 13 mm per second, until a force of 225 kg has been applied.
- 20.2.5.5 Record elevation readings of all four (4) corners of the force application plate.

- 20.2.5.6 Apply additional vertical force in the downwards direction to the force application plate at a rate not more than 13 mm per second until 50% of the specified force has been applied. Record elevation readings of all four (4) corners.
- 20.2.5.7 Continue to apply a vertical force to the application plate until the total force specified is applied. Record elevation readings of all four (4) corners.
- 20.2.5.8 With total load applied, test all doors for compliance with paragraph 20.2.3.2 and record results.
- 20.2.5.9 Remove applied load from application plate. Record elevation readings at all four (4) corners of the roof. Compare results with original readings to determine permanent deformation of the roof. Test all doors for compliance with paragraph 20.2.3.2 and record results.
- 20.2.5.10 Record all results.
- 20.2.6 Test Procedure designed for 20.2.4:
- 20.2.6.1 Place the body on either side, on a rigid horizontal surface so that the entire body is supported.
- 20.2.6.2 Apply a rigid, rectangular force application plate fitted as near as possible to the contour of the ambulance side.
- 20.2.6.3 Position the force application plate on the side of the vehicle so that its rigid surface is perpendicular to a vertical longitudinal plane and so that in the top projected view, its longitudinal centreline coincides with the longitudinal centreline of the vehicle, and it is centred on the side of the vehicle.

20.2.6.4 With all doors fully closed, apply an evenly distributed vertical force in the downward direction to the force application plate at any rate not more than 13 mm per second, until a force of 225 kg has been applied.

20.2.6.5 Record elevation readings of all four (4) corners of the force application plate.

20.2.6.6 Apply additional vertical force in the downwards direction to the force application plate at a rate not more than 13 mm per second until 50% of the specified force has been applied. Record elevation readings of all four (4) corners.

20.2.6.7 Continue to apply a vertical force to the application plate until the total force specified is applied. Record elevation readings of all four (4) corners.

20.2.6.8 With total load applied, test rear doors for compliance with paragraph 20.2.4.1 and record results.

20.2.6.9 Remove applied load from application plate. Record elevation readings at all four (4) corners of the roof. Compare results with original readings to determine permanent deformation of the side. Test rear doors for compliance with paragraph 20.2.4.1 and record results.

20.2.6.10 Record all results.

20.2.7 Test Equipment:

Use a flat, rigid rectangular force application plate that is measured with respect to the vehicles roof or side longitudinal and lateral centrelines. It shall be a minimum of 130 mm longer and 130 mm wider than the ambulance roof/side. For the purposes of these measurements, the ambulance roof/side is that structure, seen in the top projected view that coincides with the patient compartment of the ambulance or storage area of the support vehicle.

20.3 HVAC Performance Tests

20.3.1 Scope:

This performance standard establishes the three (3) separate performance requirements for the Heating, Ventilation and Air conditioning (HVAC) Systems of ambulances.

20.3.2 HVAC Requirements:

20.3.2.1 Vehicles shall be equipped with heating, ventilating and air conditioning systems that can be made to collectively operate using recirculated air and ambient air, and shall be capable of maintaining interior temperature within the established comfort zone of 20°C to 25°C when operating between minus (-) 30°C to plus (+) 35°C ambient.

20.3.2.2 Vehicles shall be supplied as tested.

20.3.3 Heating System Requirements:

20.3.3.1 The heating system(s) shall have sufficient capacity to simultaneously raise the temperature in the vehicle cab and patient compartment to a minimum dry bulb temperature of 20°C, at all 10 test points (9 in patient compartment and one in cab), within 30 minutes of the engine reaching operating temperatures. The temperature gradient within the nine thermocouples in the patient compartment shall not exceed 5°C at completion of the test.

20.3.3.2 The vehicle (with doors open) shall be cold soaked for a sufficient period so as to obtain a temperature reading of -30°C +2.5°C, in both compartments and that temperature held to the commencement of the time measurement (i.e. engine at operating temperature). Start engine with transmission in park or neutral, allow engine to come up to operating temperature range as specified by the OEM, then run at the high idle setting, as permitted by the OEM, and commence time measurement.

20.3.3.3 Time and temperatures shall be recorded from nine (9) equally spaced test thermocouples in the patient compartment and a single test thermocouple located at the horizontal and vertical planes in the vehicle cab. At a minimum verification readings shall be recorded at each noted time interval until test is successfully completed or failure declared after 30-minute mark:

- (1) at vehicle (engine) start time;
- (2) engine at operating temperature range or when the reading at one or more thermocouples raises to -27.5°C (start of test time measurement);
- (3) 15-minute mark; and
- (4) 30-minute mark.

20.3.3.4 In the patient compartment the nine (9) thermocouples, in stacks of three, shall be positioned as follows:

- (a) The horizontal axis shall be located at the centreline of the vehicle chassis and one stack each of three thermocouples shall be located at the one quarter, mid and three quarter point distances between the rear doors and bulkhead; and
- (b) In the vertical plane, one thermocouple shall be located at the one quarter, mid and three quarter point distances between the finished floor and the underside of the ceiling in each stack.

20.3.3.5 Heating equipment may be in (air) recirculation mode and all compartment openings, including partition door/windows and exhaust vents shall be closed.

20.3.3.6 Testing shall be certified by a Registered Professional Engineer

20.3.4 Air Conditioning System Requirements:

20.3.4.1 The air conditioning system(s) shall have sufficient capacity to simultaneously lower the temperature at midpoints of the driver and patient compartments to a dry bulb temperature of 23°C within 30 minutes of the engine being started. The temperature gradient within the vehicle shall not exceed 5°C at completion of the test.

- 20.3.4.2 The vehicle (with doors open) shall be heat soaked for a sufficient period so as to obtain a temperature of +35°C / -2.5°C in both compartments and that temperature held to start time, then the engine is started, and allowed to run at high idle setting while the transmission is in park or neutral and commence time measurements.
- 20.3.4.3 A minimum of three verification readings of time and temperature shall be recorded (vehicle start time, 15-minute mark, and final time) at thermocouple placement as specified in paragraph 20.3.3.3.
- 20.3.4.4 Air conditioning equipment may be in air recirculation mode and all compartment openings, including partition doors/windows shall be closed.
- 20.3.4.5 The test shall be conducted with a coolant system charge that does not exceed pressures recommended by the OEM. The system pressure at start and finish of the test shall be recorded.
- 20.3.4.6
- 20.3.4.6 Testing shall be certified by a Registered Professional Engineer
- 20.3.5 Ventilation System Requirement:
Ventilation system(s) shall be capable of providing a complete change of ambient air within vehicle every 2.5 minutes with the vehicle static. Ventilation shall be separately controlled within each compartment.
- 20.3.5.1 Testing shall be certified by a Registered Professional Engineer

20.4 Pressure Vessel Retention:

20.4.1 Scope:

This performance standard specifies requirements for mounts and brackets that restrain pressure vessels including all oxygen tank holders, fire extinguisher brackets and mounts for tanks containing pressurized gases installed in ambulances or support vehicles. This is a two-part procedure: (a) tests that the bracket designed to hold the pressure vessel can withstand a 25G force and (b) the bracket mounting can withstand 10 times the weight of the bracket + 25 times the weight of a fully loaded tank(s) which the tank holder was designed to restrain. These tests can be performed together or separately and shall be documented as such with specific details of mounting hardware and locations.

20.4.2 Definitions:

"Tank Holder" means the retention system, including all hardware provided for holding the pressure vessel (tank) in the ambulance or support vehicle.

20.4.3 Requirements:

20.4.3.1 When a force equal to 25 times the weight of a fully loaded tank(s) which the tank holder was designed to restrain, plus the weight of the tank holder is applied to the tank holder, as specified in the Test Procedure, then:

- (1) The tank holder components shall not fail and/or separate along attachment points;
- (2) The tank holder or any component thereof shall not separate from the vehicle at any attachment point; and
- (3) The force application cylinder shall not disengage from the tank holder.

20.4.3.2 When a force equal to 25 times the weight of a fully loaded tank(s) which the tank holder was designed to restrain, plus 10 times the weight of the tank holder is applied to the tank holder, as specified in the Test Procedure, then:

- (1) The tank holder or any component thereof shall not separate from the vehicle at any attachment point; and
- (2) The part of the vehicle to which the tank holder is attached shall not fail and/or separate at any attachment point.

20.4.3.3 Testing shall be certified by a Registered Professional Engineer

20.4.4 Test Procedure:

20.4.4.1 Each tank holder shall be capable of meeting the specified requirements when tested in accordance with the following procedures.

20.4.4.2 Using the installed tank holder, insert the force application cylinder and apply the forces specified in sub-paragraphs (1) and (2). It is not required to simultaneously apply forces:

- (1) Apply the 25 G force required to either end of the cylinder so that the action of the force coincides with the longitudinal centreline of the cylinder, in each plane; and
- (2) Apply the required 25 G force to the cylinder in any direction, in a plane perpendicular to the longitudinal centreline of the cylinder and which passes through the location which corresponds to the location of the centre of gravity of a full tank, for which the holder is designed to restrain.

20.4.4.3 Using the installed tank holder apply the forces specified below. It is not required to simultaneously apply forces:

- (1) Apply a force equal to 25 times the weight of a fully loaded tank(s) which the tank holder was designed to restrain, plus 10 times the weight of the tank holder so that the action of the force coincides with the longitudinal centreline of the cylinder, in each plane; and

- (2) Apply a force equal to 25 times the weight of a fully loaded tank(s) which the tank holder was designed to restrain, plus 10 times the weight of the tank holder in a plane perpendicular to the longitudinal centreline of the cylinder and which passes through the location which corresponds to the location of the centre of gravity of a full tank, for which the holder is designed to restrain.

20.4.4.4 The ambient temperature may be at any level between 0°C and 35°C.

20.4.5 Test Equipment:

The force application cylinder is a rigid structure, having the same physical dimensions as the cylinder that the tank holder was designed to restrain.

20.5 Interior Sound Level Test

20.5.1 Scope:

This performance standard establishes maximum interior sound levels for the patient compartment and the cab of ambulances.

20.5.2 Requirements:

20.5.2.1 The interior sound level in the patient compartment shall not exceed 80 decibels (dB) when measured in accordance with this test performance standard.

20.5.2.2 The interior sound level in the driver compartment shall not exceed 84 decibels (dB) with the cab windows closed or 90 decibels (dB) with the cab windows open 150 mm when measured in accordance with this test performance standard.

20.5.2.3 Testing shall be certified by a Registered Professional Engineer

20.5.3 Test Conditions:

20.5.3.1 Vehicle doors, windows and vents are to be in the closed position.

20.5.3.2 Air conditioner/heater blower switch in patient and/or driver compartments shall be placed at the highest speed.

- 20.5.3.3 If the motor vehicle's engine radiator fan drive is equipped with a clutch or similar device that automatically either reduces the rotational speed of the fan or completely disengages the fan from its power source in response to reduced engine cooling loads, the vehicle may be parked before testing with its engine running at high idle or any other speed that the operator chooses for sufficient time, but not more than 10 minutes, to permit the engine radiator fan to automatically disengage.
- 20.5.3.4 Siren and all warning lights shall be turned on for full duration of each test. (Note: Siren must be sounding in the loudest mode of operation).
- 20.5.3.5 The driver is in his/her normal seated driving position and the person conducting the test is the only other person in the vehicle.
- 20.5.3.6 This test shall be performed during the following weather conditions:
- (1) Ambient temperature shall be within range of 0°C - 30°C;
 - (2) Wind velocity not to exceed 18 km/hr;
 - (3) Other meteorological conditions shall be such that they do not influence the measurements; and
 - (4) Ambient temperatures, speed and direction of wind related to vehicle's positioning shall be recorded. Date, start and finish time of testing shall also be noted.
- 20.5.4 Test Procedure:
- 20.5.4.1 Suspend the microphone vertically 150 mm above the normal position of the patient's head on the primary cot.
- 20.5.4.2 Park vehicle at a location so that no large reflecting surfaces, such as other vehicles, signboards, buildings or hills are within 15 metres of the vehicle being tested.

- 20.5.4.3 Set vehicle transmission in neutral gear and accelerate engine to 50 to 60 percent of the engine manufacturer's RPM rating. Stabilize the engine at that speed and measure the highest sound level.
- 20.5.4.4 Return engine speed to idle and repeat the process as specified above until two maximum sound levels within 2 decibels (dB) of each other is recorded. Numerically average these two maximum sound level readings. A 2 dB tolerance over the specified sound level limits is permitted to allow for variations in test conditions and capabilities of meters.
- 20.5.4.5 Repeat above requirements in driver compartment by suspending the microphone at a point 150 mm below the interior headliner mid-way between the seated positions of the driver and passenger.
- 20.5.4.6 Repeat the above requirements in the driver compartment with both the driver and passenger side windows open 150 mm.
- 20.5.5 Test Equipment:
Use a sound level meter that meets the OH&S requirements of a type 2 meter operating on the A-weighting network with a slow meter response.
- 20.6 Vehicle Weight Distribution
- 20.6.1 Scope:
This performance standard establishes requirements for distribution of the weight of an ambulance.
- 20.6.2 Definitions:
- 20.6.2.1 The definitions of gross vehicle weight rating (GVWR); curb weight; gross axle weight rating (GAWR); etc., shall be in accordance with the Canadian Motor Vehicle Act and Regulations.

20.6.2.2 "Converted Curb Weight" shall mean the actual weight of the vehicle with all standard OEM equipment; carrying its maximum capacity of fuel, oil and coolant and including the weight of the conversion and all equipment as supplied by the Contractor in accordance with the terms of this *Standard*.

20.6.2.3 "Payload Allowance" shall mean the actual weight difference determined by the subtraction of the 'Converted Curb Weight' from the 'Gross Vehicle Weight Rating'. The minimum required 'Payload Allowances' for each ambulance configuration is set out in sub-section 18.3 of the *Standard*.

20.6.3 Requirements:

20.6.3.1 The converted curb weight distribution of a properly loaded ambulance, on a level surface, shall be such that not less than thirty percent nor more than fifty percent of the vehicle's weight is on the front suspension. Where the OEM specifies a weight distribution that differs with the above, the conversion shall conform to that requirement and the Contractor shall retain a copy of the OEM specification with the test results.

20.6.3.2 The converted curb weight on the right and left wheel of each axle of the completed vehicle shall be weighed to determine weight distribution. The weight between each side should be within five percentage points. This tolerance is calculated as follows:

- (1) obtain converted curb weight of each wheel on a given axle;
- (2) divide the weight of each wheel by the total converted curb weight of the axle, times (x) 100 = percentage of weight on each side;
- (3) subtract the smaller percentage from the larger result; and
- (4) if the difference is five percentage points or less, the vehicle has complied with the required weight distribution.

20.6.3.3 The vendor shall complete the following information and submit with the test certificate:

- (1) Gross Vehicle Weight Rating _____ kg
- (2) Chassis Curb Weight Distribution:
 - (a) Chassis Curb Weight _____ kg
 - (b) Front Axle
 - Gross Axle Weight Rating _____ kg
 - Chassis Curb Axle Weight _____ kg
 - Chassis Curb Left Side Wt. _____ kg
 - Chassis Curb Right Side Wt. _____ kg
 - (c) Rear Axle
 - Gross Axle Weight Rating _____ kg
 - Chassis Curb Axle Weight _____ kg
 - Chassis Curb Left Side Wt. _____ kg
 - Chassis Curb Right Side Wt. _____ kg
- (3) Converted Curb Weight Distribution:
 - (a) Front Axle
 - Converted Curb Axle Weight _____ kg
 - Converted Curb Left Side Wt _____ kg
 - Converted Curb Right Side Wt _____ kg
 - (b) Rear Axle
 - Converted Curb Axle Weight _____ kg
 - Converted Curb Left Side Wt _____ kg
 - Converted Curb Right Side Wt _____ kg
 - (c) Converted Curb Weight _____ kg
 - (d) Payload (GVWR - Converted Curb Wt.) _____ kg

(4) Calculations:

(a) Front/Rear weight distribution calculated as per paragraph 20.6.3.1

Percent weight on front axle = _____%

(b) Front axle left/right weight distribution per paragraph 20.6.3.2

Percent difference side to side = _____%

(c) Rear axle left/right weight distribution per paragraph 20.6.3.2

Percent difference side to side = _____%

20.6.3.4 The use of ballast to achieve proper weight distribution is not permitted.

20.6.3.5 Testing to be certified by the Contractor.

20.7 Centre of Gravity Location:

20.7.1 Scope:

This performance standard establishes requirements for the location of the Actual Centre of Gravity of an ambulance.

20.7.2 Requirements:

20.7.2.1 The Contractor shall calculate the location of the Actual Centre of Gravity (ACG) of the fully converted ambulance.

20.7.2.2 The Contractor shall certify that the ACG is at or below the maximum height as set out by the chassis manufacturer, and is in compliance with the longitudinal and lateral limits set by the chassis manufacturer.

20.7.2.3 The use of ballast to achieve proper location of the ACG is not permitted.

20.7.2.4 Testing shall be certified by a Registered Professional Engineer

20.8 12 Volt dc Electrical System Performance

20.8.1 Scope:

This performance standard establishes performance requirements and certification criteria for the 12 Volt dc electrical systems of ambulances.

20.8.2 Application:

Each ambulance shall be tested and a certificate explaining the results shall be presented to the Purchaser at time of delivery.

20.8.3 Requirements:

20.8.3.1 The generating system shall produce the maximum required output at the regulated voltage and at an engine speed not to exceed the OEM recommended high idle speed. A minimum under hood temperature of 93°C shall be achieved during the test period. If the 93°C is not achievable it must be clearly stated reasons along with maximum temperatures obtained during test.

20.8.3.2 The test certificate that is presented to the Purchaser shall confirm that the ambulance was tested as delivered and that the generating system is capable of supporting the mandatory continuous current loads as per the requirements of this performance standard.

20.8.3.3 If the ambulance is equipped with a 12V dc load management system, then the ambulance shall be tested in the condition which imposes the maximum electrical current load while the load management system is operating. The certificate in paragraph 20.8.3.2 shall clearly state that the maximum load was restricted by a load management system and shall explain which electrical functions listed in paragraph 20.8.4.1 were turned off or altered by the load management system in order to restrict the load.

20.8.3.4 Testing to be certified by the Contractor.

20.8.4 Test Procedures:

20.8.4.1 For the purpose of this test, the following systems (loads), turned on simultaneously, shall constitute the maximum required output referred to in paragraph 20.8.3.1:

- (1) ignition system;
- (2) headlights (low beam) and all CMVSS running lights;
- (3) windshield wipers (low speed);
- (4) cab air conditioning (at coldest setting with highest blower speed);
- (5) 2-way radio in receive mode (or 5 amp load if radio not installed);
- (6) patient compartment ceiling lighting (on high setting);
- (7) patient compartment air conditioning (at coldest setting with highest blower speed);
- (8) emergency warning light system on primary mode and wig-wags on;
- (9) 10 amp medical load or equal;
- (10) left and right scene lights;
- (11) rear scene light;
- (12) any optional fixed electrical loads specified by the Purchaser beyond the scope of this *Standard*; and
- (13) any optional variable electrical loads specified by the Purchaser beyond the scope of this *Standard* set to 60% of rated maximum.

20.8.4.2 Ammeters shall be installed to separately measure the maximum load imposed on the conversion battery(s) and on the OEM battery(s).

20.8.4.3 Voltmeters shall be installed to separately monitor the voltage of the OEM battery(s) and the conversion battery(s).

20.8.4.4 The engine shall be started and set to a speed (in compliance with paragraph 20.8.3.1) which will maintain the voltage at both the conversion and the OEM batteries between 12.8 and 15 volts for the duration of the test.

20.8.4.5 The engine shall be run for fifteen minutes. At the end of fifteen minutes, all the loads listed in paragraph 20.8.4.1 shall be turned on and the test period shall begin. The test period shall be fifteen minutes.

20.8.4.6 The ammeter readings (in amps) shall be recorded at the beginning and the end of the test period.

20.8.4.7 The voltage at each battery (or battery bank) shall be monitored for the duration of the test. The highest and lowest voltage reading of each battery (or battery bank) shall be recorded.

20.8.4.8 The higher of the two readings on each ammeter shall be added to obtain the maximum required output of the 12V dc electrical system. The maximum required output shall be compared to the maximum 12V dc current rating at 93°C and 14V dc of the generating system.

20.8.5 Test Conditions:

20.8.5.1 The ambulance shall be complete and ready for delivery including all equipment as specified by the Purchaser.

20.8.5.2 The OEM and conversion batteries shall be fully charged.

20.8.5.3 Ambient temperature shall be a minimum of 21°C.

20.8.5.4 The engine shall be warmed up to operating temperature prior to the test period and an under hood temperature of 93°C minimum shall be achieved during the test.

20.9 Electro Magnetic Radiation Suppression Test

20.9.1 Scope:

This performance standard establishes performance requirements and certification criteria for limiting electromagnetic radiation.

20.9.2 Requirements:

20.9.2.1 All electric devices and equipment installed, which produces electromagnetic radiation, shall include filters, suppressors or shielding to prevent radio frequency (RF) interference to radios and other electronic equipment.

20.9.2.2 The ambulance shall be tested and certified in accordance with the intent, procedures and limits as set out in SAE J551/4.

20.9.2.3 Testing to be certified by the Contractor.

20.10 Antennae Ground Plane Test:

20.10.1 **Intentionally Deleted**

20.10.2 Antenna Ground Plane:

20.10.2.1 The antenna ground planes shall be checked by the Contractor to ensure that they are properly grounded to the chassis of the vehicle. This can be done by measuring the continuity between the ground plane and the top rail (chassis). The resistance measurement shall show zero ohms on the meter.

20.10.2.2 The resistance between the ground plane and the negative battery shall not exceed 0.5 ohms.

20.10.3 Testing to be certified by the Contractor.

20.11 Interior Lighting Test

20.11.1 Scope:

This performance standard establishes the minimum interior illumination level for the patient compartment of ambulances.

20.11.2 Requirements:

Normal white illumination within the patient compartment shall not be less than:

- (1) 160 Lux (lx) measured along the centreline of the clear floor located in the area between the rear and side doors; and
- (2) 376 lx on at least 90% of the surface area of the main cot(s).

20.11.2.1 These limits shall be achieved without outside ambient light and with the Patient Compartment Lights operating at the "high" setting.

20.11.2.2 Testing shall be certified by a Registered Professional Engineer

20.11.3 Test Procedures

20.11.3.1 With the cot installed and top of the cot marked into squares not larger than 15cm x 15cm, use of a flat non-reflective surface placed on top of the stretcher is permitted.

20.11.3.2 Record readings from the centre of each square.

20.12 Oxygen System Pressure Test

20.12.1 Scope:

This performance standard establishes the test requirements for the on board oxygen system.

20.12.2 Requirements:

20.12.2.1 Every ambulance shall be tested and a certificate presented to the Purchaser at time of delivery.

20.12.2.2 Testing to be certified by the Contractor.

20.12.3 Test Procedure:

20.12.3.1 When system is completed, a cylinder of medical air, nitrogen gas or equal with pressure regulator set to delivery 1034 kPa will be connected to the oxygen system inlet. Turn the cylinder on to pressurise the system and inspect all joints for leaks. Correct any leaks noted.

20.12.3.2 Attach a pressure gauge (0-1380 kPa) securely to the oxygen outlet at the action wall.

20.12.3.3 Pressurise the system to 1034 kPa and turn off the cylinder leaving it attached to the inlet connector for a minimum of thirty minutes. No drop in system pressure is allowed.

20.12.3.4 After successful completion of testing, the system shall be capped with plastic end caps and tagged with a certificate tag showing:

- (1) Start time;
- (2) Initial pressure;
- (3) End time;
- (4) Final pressure;
- (5) Date; and
- (6) Signature of tester.

20.13 **Intentionally Deleted** |

20.14 **Intentionally Deleted** |

20.15 Body Door Components Test

20.15.1 Scope:

This performance standard shall establish requirements for the testing of all body door retention components on the side entry door and rear door(s) as installed.

20.15.2 Application:

This performance standard shall apply to all ambulances when the side entry and/or rear doors are supplied and installed by other than the OEM.

20.15.3 Requirements:

20.15.3.1 Each door shall be tested and certified for compliance to CMVSS 206 and all other relevant CMVSS Regulations.

20.15.3.2 Testing shall be certified by a Registered Professional Engineer

20.16 Emergency Lighting Requirements

20.16.1 Scope:

This performance standard establishes minimum performance of an individual emergency warning light and the primary emergency lighting system.

20.16.2 Requirements:

20.16.2.1 Each individual emergency light utilized as part of the primary emergency lighting system shall meet or exceed SAE J845 ‘Optical Warning Devices for Authorized Emergency, Maintenance, and Service Vehicles’.

20.16.2.2 The primary emergency light system shall be measured and certified to meet or exceed per requirement set as set in this Standard document and SAE J2498 sections 1 to 5 inclusive, 6.2 and 7 of ‘Minimum Performance of the Warning Light System used on Emergency Vehicles.’

20.16.2.3 The minimum optical requirements for any size of vehicle shall be as stated in table below;

Minimal Optical Power Requirement for Emergency Vehicles

Zones	Level	Zone Total at H	Min. Value at Any H Point	Min. Value at Any +/-5° Point
A	Upper	1,000,000	10,000	3,500
B	Upper	400,000	10,000	3,500
C	Upper	800,000	10,000	3,500
D	Upper	400,000	10,000	3,500
A	Lower	150,000	3,750	1,300
BF	Lower	75,000	3,750	1,300
DF	Lower	75,000	3,750	1,300

NOTE: All values are in candela-seconds/minute.

H = Horizontal lane passing through the centre of the light source.

20.16.2.4 Permissible Colours by zone while Primary Emergency lights operating:

<u>Colour</u>	<u>Zones</u>
Red	Any Zone
White	Any Zone
Blue	Not Permitted
Yellow	Not Permitted

20.16.2.5 Testing shall be certified by a Registered Professional Engineer

20.16.3 Test Reports:

As a minimum the test reports shall include:

- (1) Detailed layout of light locations on the vehicle;
- (2) Details of each light that is part of the primary circuit including make, part number and colour;
- (3) Detailed flash rate and pattern;
- (4) Detailed switching parameters;
- (5) Separate list of equivalent substitutions by location if desired; and
- (6) Clear statement of compliance to SAE J845, relevant sections of J2498 and this Standard.

20.17 Carbon Monoxide Levels

20.17.1 Scope:

This performance standard establishes performance requirements for maximum levels of concentration of carbon monoxide (CO).

20.17.2 Requirements:

20.17.2.1 Determine the CO content in the ambient air and the vehicle through a series of operating performance test periods.

20.17.2.2 The resultant difference between the highest readings in each of the three (3) operating states and the average ambient condition shall not exceed 10 ppm of CO.

20.17.2.3 Testing shall be certified by a Registered Professional Engineer

20.17.3 Test Conditions:

20.17.3.1 Calibrate equipment at start of test

20.17.3.2 Open vehicle doors and auxiliary windows and ventilate with fresh air for 10 minutes with engine off.

20.17.3.3 Do not conduct testing during high wind periods (above 25 kph) or during any type of precipitation.

- 20.17.4 Test Procedure:
- 20.17.4.1 Sample ambient air around vehicle and record.
- 20.17.4.2 Close windows and doors, start and idle engine in parked position for 10 minutes then perform following measurements.
- 20.17.4.3 Monitor CO, in the driver compartment, around doors, windows, floor, engine cowling and openings from engine compartment for the first 5 minutes and record results.
- 20.17.4.4 Monitor CO, in patient compartment, at head of main cot for the remaining 5 minutes and record results.
- 20.17.4.5 Drive the vehicle for 10 minutes on traffic laden city streets (urban speeds of 30 to 60 kph).
- 20.17.4.6 Repeat sampling during drive time as stated in paragraphs 20.17.4.3 to 20.17.4.4 and record results.
- 20.17.4.7 Then drive the vehicle for 10 minutes at highway speeds of 80 to 100 kph, repeat samplings during drive time in the driver compartment and at head of main cot and again record results.
- 20.17.4.8 Stop vehicle and repeat paragraph 20.17.4.1.
- 20.17.5 Test Equipment:
- 20.17.5.1 MSA Model I or Model II CO monitor or equivalent instrument with an accuracy of +/- 4%.
- 20.17.5.2 Detail how meter was calibrated at start of test and confirm at end.

20.18 Load Test for Grab Rail/Handles

20.18.1 Scope:

This performance standard establishes the minimum static load requirements for all grab rails and grab handles.

20.18.2 Requirement:

20.18.2.1 A grab rail or grab handle shall not detach, loosen or deform during the load application of 135 kg in noted directions.

20.18.2.2 Testing shall be certified by a Registered Professional Engineer

20.18.3 Test Procedure - Grab Rail:

20.18.3.1 With the vehicle parked on a flat surface, measure the grab rail for straightness and the space between top sides of rail and headliner or supporting cabinetry.

20.18.3.2 Attach a force application device to the grab rail at a midpoint between two securing points and incrementally apply the required in a plane parallel to the fasteners for the rail. Hold the load for two (2) minutes and release.

20.18.3.3 Repeat paragraph 20.18.3.2 at a least one other midpoint between two securing points.

20.18.3.4 Repeat the above test procedures applying the load perpendicular to the initial plane

20.18.3.5 Examine and measure the grab rail for loosening or bending and record results.

20.18.4 Test Procedure - Grab Handles:

20.18.4.1 Attach a force application device to the midpoint of the grab handle and incrementally apply the required in a plane parallel to the fasteners for the handle.

20.18.4.2 Repeat the test procedures applying the load perpendicular to the initial plane.

20.18.4.3 Examine the grab handle for loosening and record results.

20.18.4.4 The above test procedures shall be completed for each different material the grab handles are secured to.

20.19 Siren/Public Address System Sound Levels

20.19.1 Scope:

This performance standard establishes the minimum sound level output for the siren / public address system.

20.19.2 Requirements:

20.19.2.1 The siren shall be capable of producing a continuous warning sound at a minimum level of 123 dBA, A-weighted, at 3 meters, on axis, in the "wail" mode with "yelp" capable of producing a continuous warning sound at a minimum level of 122 dBA with 13.6 v +/- .2 input, at a frequency in the range of 500 to 2000 Hz maximum.

20.19.2.2 Testing shall be certified by a Registered Professional Engineer

20.19.3 Test Conditions:

20.19.3.1 Vehicle doors, windows and vents are to be in the closed position.

20.19.3.2 Siren shall be sounded in its loudest mode of operation

20.19.3.3 This test shall be performed during the following meteorological conditions:

- (1) Ambient temperature shall be within range of 0°C to 30°C;
- (2) Wind velocity not to exceed 18 km/hr;
- (3) Other meteorological conditions, e.g. rain, fog, etc shall be such that they do not influence the measurements; and
- (4) Ambient temperatures speed and direction of wind related to vehicle's positioning shall be recorded. Date, start and finish time of testing shall also be recorded.

20.19.4 Test Procedure:

20.19.4.1 Position the meter on a horizontal plane 3 meters forward of the centreline of the vehicle's hood and one meter above ground level.

20.19.4.2 Park vehicle at a location so that no large reflecting surfaces, such as other vehicles, signboards, buildings or hills are within 15 metres of the vehicle being tested.

20.19.4.3 Set vehicle transmission in neutral gear and accelerate engine to 50 to 60 percent of the engine manufacturer's RPM rating. Stabilize the engine at that speed, turn on siren and measure the highest sound level.

20.19.4.4. Return engine speed to idle and repeat the process as specified above until two maximum sound levels within 2 decibels (dB) of each other are recorded. Numerically average these two maximum sound level readings and the average.

20.19.5 Test Equipment:

Use a sound level meter that meets the OH&S requirements of a type 2 meter operating on the A-weighting network with a slow meter response

20.20 Incubator Restraint Load

20.20.1 Scope:

This performance standard establishes performance requirements for the incubator rear tie-down fixture(s).

20.20.2 Requirements:

20.20.2.1 The incubator rear tie-down fixtures(s) shall not detach, loosen or deform during the application of a force of 11,100 Newton.

20.20.2.2 Testing shall be certified by a Registered Professional Engineer

20.20.3 Test Procedures:

20.20.3.1 The test load shall be applied forward and upward at an angle of 45 degrees above the plane of the ambulance floor.

20.20.3.2 Examine and measure the rear tie-down fixture(s) for compliance.

20.21 Passenger and Patient Safety Restraints Load

20.21.1 Scope:

This performance standard establishes requirements for passenger and patient safety restraints.

20.21.2 Requirements:

20.21.2.1 All seat belts and seats installed by the Contractor for the use of seated passengers shall be tested and certified for compliance to CMVSS 207, 208, 209, 210 and all other relevant CMVSS regulations. Where there is no regulation under CMVSS (such as a side-facing seat) the material and design shall meet the spirit of CMVSS regulations for passenger restraint. All installations shall be tested to the relevant CMVSS standards.

20.21.2.2 Seat belts installed by the Contractor to restrain patients in a prone position shall be tested and certified to the intent of CMVSS 210 by the application of a total force of 22,240 Newton divided equally between the seat belt assemblies. Each seat belt assembly may be tested independently.

20.21.2.3 Testing shall be certified by a Registered Professional Engineer

20.22 10 G restraint test

20.22.1 Scope:

This performance standard establishes the minimum static load requirements for securing equipment or material weighing over 14kg (30lbs) within the vehicle.

20.22.2 Requirements:

20.22.2.1 When a force equal to 10 times the weight of the intended equipment or material, plus the weight of the restraint is applied to the restraint then;

- (1) restraint shall not fail and/or separate along attachment points;
- (2) The restraint or any component thereof shall not separate from the vehicle at any attachment point;

20.22.2.2 Testing shall be certified by a Registered Professional Engineer

20.22.3 Test Procedure:

20.22.3.1 Attach a force application device to the restraint and incrementally apply the required load in a plane parallel to the fasteners.

20.22.3.2 Repeat the test procedures applying the load perpendicular to the initial plane.

20.22.3.3 Examine restraint and record results.

20.22.3.4 The above test procedures shall be completed for each different material the restraint is secured to.

20.23 Occupant Restraint Load Test

20.23.1 Scope:

This performance standard establishes the minimum static load requirements for the occupant restraint device and its fasteners.

20.23.2 Requirements:

20.23.2.1 Fasteners shall be tested and certified to withstand a force by the application of a total force of 22,240 Newtons divided equally between the fasteners securing occupant device.

20.23.2.2 The occupant restraint device installed at side facing seats by the Contractor to comply with this standard shall be tested and certified to withstand a force of 13,344 Newtons.

20.23.2.3 Testing shall be certified by a Registered Professional Engineer

20.23.3 Test Procedure - Fasteners:

20.23.3.1 Attach a force application device to the fastener, apply the required load in a plane parallel to the fastener

20.23.3.2 Repeat the test procedures applying the load perpendicular to the initial plane.

20.23.3.3 Examine fastener(s) and record results.

20.23.3.4 The above test procedures shall be completed for each different material the fastener is secured to.

20.23.4 Test Procedure - occupant restraint

20.23.4.1 Apply a force in a forward direction at the centre of the device using a suitable solid block to distribute the load.

20.23.4.2 Examine restraint device & fastener(s) and record results.

20.24 Occupant Head Protection Zone

20.24.1 Scope: This test establishes the minimum acceptable dimension for a occupant seating position.

20.24.2 Purpose: To ensure the measurement of the occupants head protection zone is preformed correctly for all makes/models of Ambulances.

20.24.3 Definitions:

20.24.3.1 “Seating postion” is any seating space that provides a seat belt to restraint occupant.

- 20.24.3.2 “Head protection zone” is the space above a seating position that is to be free of contact surfaces.
- 20.24.3.3 “Test Fixture” is a ridged rectangular structure weighing not more than 27kg and has the following dimensions, 1093mm (43”) high x 458mm (18”) wide x 381mm (15”) deep (All dimensions have a tolerance of +/- 2mm). Fixture is to be clearly marked, with TOP and FRONT as illustrated in figure #1.

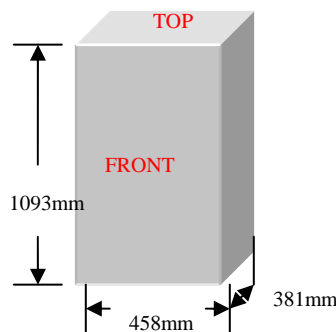

Figure #1

20.24.4 Requirements:

- 20.24.4.1 Each seating position within the patient’s compartment shall be validated using the test fixture.
- 20.24.4.2 Pictures are to part of test report for each seating position.
- 20.24.4.3 Testing to be certified by the Contractor.

20.24.5 Test procedure:

- 20.24.5.1 Vehicle to be parked on a level surface
- 20.24.5.2 All seating positions shall have finished cushions installed
- 20.24.5.3 For each seating position place the test fixture (top up) onto the seat, front of fixture faces the direction of the intended occupant. Test Fixture must not overhang front of the seat cushion. **(Type 2 ambulances are permitted to overhang seat cushion provided restriction is not a contact surface within the head protection zone 20.24.3.2).**
- 20.24.5.4 No permanent objects are permitted to be in contact with the test fixture.
- 20.24.5.5 Document test and record results

ANNEX A

**EMERGENCY RESPONSE VEHICLE
REQUIREMENTS**

**Ontario Provincial Land Ambulance
& Emergency Response Vehicle
Standard**

VERSION 4.1 – July 15, 2010

**Emergency Health Services Branch
Ministry of Health and Long-Term Care**

ANNEX A

EMERGENCY RESPONSE VEHICLE REQUIREMENTS

A1. SCOPE

Annex A describes the minimum acceptable requirements for emergency response vehicles (ERV) intended for use in ambulance services in the Province of Ontario.

A2 DEFINITIONS

A2.1 "Emergency Response Vehicle" (ERV) shall have the same meaning as defined in Ontario regulation 257/00 and the vehicles that are recognized as ERVs under this *Standard* shall consist of the following:

- (1) "ERV - responder" shall mean a vehicle operated by a certified ambulance service that responds on a regular basis to emergency medical incidents.
- (2) "ERV support" shall mean an equipment and supply carrier that responds to support ambulance service operations at major emergency medical incidents
- (3) "ERV command" shall mean a vehicle that responds to provide operational command and control functions for major emergency medical incidents.

A3. GENERAL REQUIREMENTS

A3.1 Each ERV shall comply with the following documents, listed in order of precedence:

- (1) the Canadian Motor Vehicle Safety Standards (CMVSS);
- (2) Applicable sections of the HTA;
- (3) **Except where exemptions apply, the** applicable sections of the Ontario Provincial Land Ambulance & Emergency Response Vehicle Standard (the *Standard*);
- (4) any criteria established by the OEM for the conversion of chassis to emergency vehicles; and
- (5) all relevant Standards and Recommended Practices of technical

agencies and bodies referred to in the *Standard*.

- A3.2 The documents referenced in sub-section A2.1 shall be those documents that were in effect no earlier than when the motor vehicle chassis was manufactured and no later than when the vehicle was completed as an ERV.
- A3.3 Each ERV shall be complete with the operating accessories as required herein; furnished with such modifications and attachments as may be necessary to enable the vehicle to function reliably and efficiently in its intended operating environment.
- A3.4 The design of the vehicle and the required equipment installations shall maximize the safety and security of the occupants.
- A3.5 Each ERV purchased by the Ministry of Health and Long-Term Care, Emergency Health Services Branch or the former Municipality of Metropolitan Toronto on or before December 31, 1997 and approved as such on December 31, 1997 shall be deemed to be in compliance with the *Standard* and Annex A.
- A3.6 Each ERV certified for use in Ontario under previous versions of the *Standard* shall be deemed to continue to be certified under the current version until sold or modified in contravention of the version in effect at the time of the change.

A4. EXTERIOR IDENTIFICATION

A4.1 Objective

- A4.1.1 **The visual identity design of the ERV shall promote the safety of the occupants of the ERV and other motorists or bystanders by providing the best possible the visibility of the ERV.** The exterior and markings shall readily identify the vehicle as an Emergency Response Vehicle to all observers. This identification, in conjunction with the activated emergency warning systems, shall prompt the need to yield the right of way in the public's mind.

A4.2 Exterior Markings

A4.2.1 The exterior markings and design of an ERV – Responder vehicle shall readily identify the vehicle as an Emergency Response Vehicle to all observers. This identification, in conjunction with the activated emergency warning systems shall alert the public to the purpose and need to yield the right of way to this vehicles.

A4.2.2 The exterior markings and design of an ERV – support vehicle shall readily identify the vehicle as an Emergency Response Vehicle to all observers. This identification, in conjunction with the activated emergency warning systems shall alert the public to the purpose and need to yield the right of way to this vehicle.

A4.2.3 An ERV - Command vehicle shall comply with the certified ambulance service’s municipally approved Visual Identification Program and may with the written authorization of the municipality be exempt from exterior markings as identified in A.4.1.1 and A4.2.4.

A4.2.4 The individual colours and materials used in the exterior identification package ERV may vary in accordance with the certified ambulance service’s municipally approved Visual Identification Program

A3.1.2 **Intentionally Deleted**

A3.1.3 **Intentionally Deleted**

A5. EMERGENCY WARNING SYSTEM

A5.1 Design Parameters

- A5.1.1 The emergency warning system must provide the vehicle with all round conspicuity, be highly perceptible and have attention getting audio and visual signals for the safety of the ERV occupants and the public.
- A5.1.2 The emergency lighting system shall utilize flashing lights and/or rotating beacons.
- A5.1.3 The emergency lighting system design shall follow the principle that:
- (1) white (clear) light will be used to gain the viewer's attention, red light will convey the "emergency" message, amber light will convey the "caution" message;
 - (2) no colour other than red, white and amber shall be used; and
 - (3) any flashing lights of the same light type (e.g. incandescent, halogen strobe or Neobe®) shall flash all lamps of the same colour together then alternate to the other colour along the same side and plane; and
 - (4) the exemption to 10.1.3 (3) are:
 - (i) the white grille lights, these lights are not required to flash in or with any other lights on the vehicle,
 - (ii) when so equipped, traffic directional devices (sub-section 10.10) and
 - (5) amber light(s) shall not flash at the same time as other emergency lights facing in the same direction.
- A5.1.4 The system shall be comprised of components and devices that comply with the requirements of SAE J575, J576, J578, J591, J595, J1318 and J1889 as applicable to the unit.

A5.1.5 The primary emergency lighting system shall achieve all criteria and performance testing standards as detailed at Section 20 of the *Standard*.

A5.1.5.1 The primary emergency lights shall include 360 Degree warning lights, red grille lights and any other light required lighting to meet the testing requirements as detailed in section 20 of the *Standard*.

A5.1.5.2 The primary Emergency lights shall be operated independently by a switch accessible to the driver.

A5.2 360 Degree Warning Lights

A5.2.1 There shall be an array of red and white flashing or rotating lights installed on the ERV body which are visible for 360 degrees around the vehicle. This array shall include two (2) red and one (1) white light. The white light shall be located toward the vehicle centreline.

A5.3 Grille Lights

A5.3.1 Red and white warning lights shall be installed on the vertical plane of the grille such that the lights are visible in the rear view mirror(s) of a standard passenger car preceding the ERV.

A5.3.2 The red grille lights shall consist of two (2) flashing lights or a single rotating or oscillating beacon.

A5.3.3 The white grille lights shall consist of two (2) lights (which may be the high beam of the OEM headlights when permitted by the OEM) which flash in an alternating or random sequence. These lights are exempt from meeting the requirements in paragraph A4.1.3 (3). Alternatively, the white grille light may be a single rotating or oscillating beacon. The white grille light(s) shall be wired to operate independently of the other warning lights and controlled by a separate switch on the driver's console.

A5.4 Siren - Public Address System

A5.4.1 A combination siren and public address system, capable of producing high/low horn tones and other warning sounds complete with microphone and speaker, shall be installed.

A5.4.2 The siren-public address system shall meet the performance standard in section 20.

A5.5 Backup Warning Alarm

A5.5.1 A heavy duty reverse warning signal shall be installed to operate when the gear selector is in "REVERSE".

A5.5.2 **For silent backing, a disable switch may be installed; however, this switch must be programmed to reset automatically prior to the lapse of 60 seconds from the time the switch is disabled.**

A6 2-WAY RADIO INSTALLATIONS

A6.1 General

A6.1.1 The ERV design shall provide for the installation of radio equipment.

A6.1.2 The term "radio equipment" shall include all peripheral equipment associated with the radio, including:

- (1) **mobile radio unit which consists of the mobile radio transceiver or the FleetNet mobile radio repeater package VHF/ UHF mobile repeater pkg;**
- (2) **front control head, microphone and speaker front control head;**
- (3) **all associated antennas (the number will depend on the mobile radio unit, (minimum 1, 2 antennas with the radio repeater) all associated antennas;**
- (4) **cables between the control head, speaker, mobile radio unit, battery and antenna. control cables between the control head and any interface box;**

A6.2 **Radio Equipment Mounting**

A6.2.1 **The ERV shall have a designated area for mounting radio equipment which:**

- (1) provides adequate access for installation or removal and periodic maintenance;**
- (2) provides protection from physical damage; and**
- (3) is ventilated.**

A6.2.2 **A mounting position shall be provided for the radio control head and microphone clip in the cabdriver's area that allows equal access for either the driver or passenger.**

A6.2.3 **The mounting of radio equipment shall not interfere with other control functions or block vents, or block the line of sight for gauges or instruments or interfere with air bag type passenger restraint systems.**

A6.3 **Antenna Ground Plane**

A6.3.1 **In vehicles equipped with a non-metallic roof, an antenna ground plane, minimum of 1m wide x 2 m long, shall be moulded into the roof.**

A6.3.2 **The ground plane shall be grounded to the vehicle frame.**

A6.3.3 **To enable installation of an antenna mount, the total thickness of the roof and ground plane shall not exceed 10 mm for a 75 mm diameter circle at each antenna mount point.**

A6.3.4 **At each antenna mount point, the lower surface of the ground plane shall be exposed to enable contact with the antenna mount.**

A6.4 **Cable Routing**

A6.4.1 A means shall be provided to protect cables between the radio repeater and the radio control head equipment from wear and damage. This may include passages between sections of cabinetry and/or fixed conduits (with minimum inside dimension 75x50 mm) and/or removable channels (with minimum inside dimension 60x35 mm).

A6.4.2 Maximum cable routing length between radio control head and mobile radio repeater unit shall not exceed 5.2m (17ft).

A6.5 **Installation of Radio Equipment**

A6.5.1 All radio equipment shall be installed so that all fasteners and other means of attachment used in the installation/relocation into the ERV shall be designed so as to provide a minimum restraining force of 10 times the weight of the component and/or object being secured.

A6.5.2 All attachments shall be fastened in a manner that will preclude unintentional loosening.

A6.5.3 Mounting of radio equipment shall not interfere with other control functions, block vents or instruments or interfere with air bag passenger restraint systems.

A6.5.4 Documentation confirming installation compliance with this section shall be kept on file by the operator for inspection by the Ministry.

A7. **STORAGE**

A7.1 Each ERV shall be designed with adequate storage arrangements to safely contain the minimum mandatory equipment specified by the PES.

A7.1.1 One (1) fire extinguisher, 5lb C-UL approved; rating 3-A, 10 BC; rechargeable type with pressure gauge & service inspection tag shall be supplied and installed.

A7.2 All equipment or material carried in the cab or passenger compartment of an ERV shall be appropriately secured to ensure the safety of the occupants. Storage compartments, securing straps, brackets and/or cargo nets shall be capable of retaining 10 times the total weight of equipment or material they are designed to restrain. The total capacity of each retainer shall be clearly labelled.

A7.3 Regardless of location, all oxygen cylinder cradles and fire extinguisher brackets shall be designed and mounted to comply with all criteria for pressure vessel retention as detailed in section 20 in the Standard.

A8. CERTIFICATION OF AN EMERGENCY RESPONSE VEHICLE

A8.1 General

The operator shall ensure that ERV's intended for use in Ontario are in compliance with the version of the Standard in effect at the time of conversion of the vehicle

A8.2 Certification

A8.2.1 The operator either directly, through a Contractor, or indirectly through a third party shall ensure that all necessary compliance testing is undertaken and completed. The Ministry will not issue compliance certification for ERVs.

A8.2.2 If an Ambulance is converted into a ERV than only those areas modified to fit this new role shall require certification the remainder of the unit shall be deemed to be in compliance with the *Standard* and Annex A, providing the ownership remains unchanged.

A8.2.3 It is mandatory to remove/cover the word ambulance while operating in the ERV role.

A8.3 Certificates and Reports

A8.3.1 The operator shall retain on file copies of all currently valid test certificates required under the Performance Standards (Section 20) The operator shall be responsible for obtaining contractors information if requested by the Ministry for review while the vehicle remains in service

A8.3.2 The Contractor shall retain on file the original copy of all currently valid test certificates required under the Performance Standards (Section 20) and complete technical reports in support of those certificates.

A8.4 Mandatory Testing for ERVs

A8.4.1 The following tests shall be completed as stipulated in section 20

- (1) Pressure Vessel Retention (20.4)
- (2) Emergency Lighting Requirements (20.16)
- (3) Siren/Public Address System Sound Levels (20.19)
- (4) 10 G restraint test (20.22)

A8.5 Continued Compliance

A8.5.1 It shall be the responsibility of the operator to ensure that the ERV continues to be in compliance with the applicable version of the Standard.

A8.5.2 Any subsequent modifications or changes made shall be in accordance with the version of the Standard in effect at the time of the modification or change. Where modifications or changes occur to components or material that require testing under the Performance Standards, the operator shall ensure that new testing is undertaken and completed.

A8.5.3 The operator shall maintain on file all necessary documentation and new testing information related to the modified or changed ERV for inspection by the Ministry while the vehicle remains in service.

**This page has been
left
intentionally blank**

ANNEX B

**REMOUNTED AMBULANCE
TRANSFER OF PATIENT
COMPARTMENT MODULE**

**Ontario Provincial Land Ambulance
& Emergency Response Vehicle
Standard**

VERSION 4.1 – July 15, 2010

**Emergency Health Services Branch
Ministry of Health and Long-Term Care**

ANNEX B

REMOUNTED AMBULANCE TRANSFER OF PATIENT COMPARTMENT MODULE

B1. SCOPE

Annex B describes the minimum acceptable requirements for the remounting of patient compartment modules, removed from previously certified ambulances, on new or used chassis, intended for use in Ontario.

B2. GENERAL REQUIREMENTS

B2.1 Each Remount shall comply with the following documents, listed in order of precedence:

- (1) the Canadian Motor Vehicle Safety Standards (CMVSS);
- (2) the Ontario Provincial Land Ambulance & Emergency Response Vehicle Standard (the *Standard*) subject to any provisions in this Annex;
- (3) any criteria established by the OEM for the conversion of chassis to ambulances; and
- (4) all relevant SAE Standards and SAE Recommended Practises.

B2.2 The documents referenced in sub-section B2.1 shall be those documents that were in effect no earlier than when the motor vehicle chassis was manufactured and no later than when the vehicle was completed as a Remount.

B2.3 Each Remount shall be complete with the operating accessories as required herein; furnished with such modifications and attachments as may be necessary to enable the vehicle to function reliably and efficiently in its intended operating environment.

B2.4 The design of the vehicle and the required equipment installations shall maximize the safety and security of the occupants.

- B2.5 Each Remount shall be in compliance with all appropriate sections of the *Standard* saving only requirements and performance test requirements that are modified or changed in this Annex.

B3. STRUCTURAL INTEGRITY

The Contractor, prior to any other work taking place, shall verify the structural integrity of the patient compartment module.

B4. MATERIAL CHANGES

B4.1 Seats, Seat Belts & Other Occupant Safety Restraints:

- B4.1.1 All seats in the patient compartment shall be replaced in accordance with applicable requirements under CMVSS unless Transport Canada has given prior approval of an acceptable testing program that is in compliance with CMVSS. In this instance replacements will be based on test results and accordingly the seats do not have to be replaced.
- B4.1.2 All passenger seat belts in the patient compartment shall be replaced with new seat belts certified under CMVSS.
- B4.1.3 Floor and other anchor points for seats, the occupant restraint device and the incubator rear tie-down fixture shall be inspected and replaced or reinforced, if necessary, in order to comply with the applicable CMVSS requirements and the ambulance performance tests contained in this *Standard*.
- B4.1.4 All other patient safety restraints and equipment securing straps shall be inspected and replaced, if necessary, in order to comply with test restraint requirements in this *Standard*.

- B4.1.5 Where seats, seat belts and/or other occupant restraints are replaced, performance tests required under the *Standard* shall be completed and the results submitted.
- B4.2 Compartment Materials
Unless flammability-testing protocols have been approved by Transport Canada in accordance with CMVSS, all material shall either be in compliance with CMVSS 302 or shall be replaced with material that is in compliance with the requirements of the CMVSS standard.
- B4.3 Exterior Lights
- B4.3.1 All “clearance lights” required under CMVSS shall be replaced, as required, with lamps/lights that are compliant with requirements of CMVSS.
- B4.3.2 All other exterior operating and emergency lights shall be inspected and lamps, lens and reflectors replaced, as required, to comply with the CMVSS, the Ontario Highway Traffic Act and the photometric levels required under this *Standard*.
- B4.4 Body Door Components:
All door frames, fasteners, hinges and door locks shall be inspected to ensure continued compliance with CMVSS. Replacement components shall also comply with this safety standard.
- B4.5 Seat Travel
The mounting of the module on the chassis shall not alter the horizontal travel of the vehicle cab seat bases as manufactured by the OEM.

B5. CERTIFICATION

B5.1 Certification for a Remount shall be in accordance with Section 19 of the *Standard* saving only the requirement to complete Performance Standards as noted below.

B5.2 The Contractor shall inspect every patient compartment offered for remount and submit to the operator, a written statement as to whether or not there exists any condition that may cause the ambulance after remount to not be in compliance with the current Performance Standards as detailed in the *Standard* and listed below. Failure to correct noted deficiencies shall result in a non-compliant Remount.

- (1) Main Cot Retention;
- (2) Static Load Test for Ambulance Body Structures;
- (3) HVAC Performance Test;
- (4) Pressure Vessel Retention;
- (5) Interior Lighting;
- (6) Body Door Components Test;
- (7) Emergency Lighting Requirements;
- (8) Load Test for Grab Rail/Handles;
- (9) Incubator Restraint Load Test;
- (10) Passenger and Patient Safety Restraints Load Tests;
- (11) 10G restraint test
- (12) Occupant Restraint Load Test
- (13) Occupant Head Protection Zone

B5.3 The following tests shall be completed by a Registered Professional Engineer and certified as conforming to the Performance Standards.

- (1) Interior Sound Level Test;
- (2) Centre of Gravity Location;
- (3) Carbon Monoxide Levels; and
- (4) Siren/Public Address System Sound Levels.

B5.4 The following tests shall be completed by the Contractor and certified as conforming to these Performance Standards.

- (1) Vehicle Weight Distribution;
- (2) 12 Volt dc Electrical System Performance;
- (3) Electromagnetic Radiation and Suppression Test;
- (4) Antenna System Test;
- (5) Oxygen System Pressure Test

B5.5 For Remounts of an identical type, the Contractor may request Compliance Certification for all like Remounts and complete actual testing only once for all the above Performance Standards. The exceptions being the 'Oxygen System Pressure Test, that shall be completed for every Remount.

**This page has been
left
intentionally blank**

ANNEX C

**NEW AMBULANCE
COMPLIANCE CHECKLIST**

**Ontario Provincial Land Ambulance &
Emergency Response Vehicle
Standard**

VERSION 4.1 – July 15, 2010

**Emergency Health Services Branch
Ministry of Health and Long-Term Care**

ANNEX C

NEW AMBULANCE COMPLIANCE CHECKLIST

PART 1- COMPLIANCE CHECKLIST

This Checklist is to be completed in accordance with sub-section 19.1.3 (6) of the *Standard* and submitted to the Director Emergency Health Services Branch along with the other required documentation for compliance certification. Compliance or non-compliance with each requirement will be noted by (✓). In instances where any non-compliance is noted, within a section the details of the non-compliance will be provided in the Part 11 including the sub-section number.

- 1. **Scope of the Standard**..... Compliance () Non-Compliance ()
- 2. **Definitions**..... Compliance () Non-Compliance ()
- 3. **General Requirements of the Ambulance** Compliance () Non-Compliance ()
 - 3.8 110v Electrical Power Compliance () Non-Compliance ()
- 4. **Ambulance Owners Manual** Compliance () Non-Compliance ()
- 5. **Materials**..... Compliance () Non-Compliance ()
- 6. **Exterior Identification**..... Compliance () Non-Compliance ()
- 7. **Construction and Design Details** Compliance () Non-Compliance ()
- 8. **Heating, Ventilation and Air Conditioning** Compliance () Non-Compliance ()
- 9. **Low Voltage Conversion Electrical System**..... Compliance () Non-Compliance ()
- 10. **Emergency Warning System** Compliance () Non-Compliance ()
- 11. **2-Way Radio Installations**..... Compliance () Non-Compliance ()
 - 11.6 Installation of radio equipment..... **Compliance () Non-compliance ()**
- 12. **Oxygen System**..... Compliance () Non-Compliance ()
- 13. **Suction Aspiration System**..... Compliance () Non-Compliance ()
- 14. **Accommodation and Storage**..... Compliance () Non-Compliance ()
- 15. **Safety Equipment** Compliance () Non-Compliance ()
- 16. **Interior Signs and Labels**..... Compliance () Non-Compliance ()

17. Modular Ambulance Body - Type 1 and 3	Compliance () Non-Compliance ()
18. Ambulance Chassis Specifications	Compliance () Non-Compliance ()
19. Certification of an Ambulance Model	Compliance () Non-Compliance ()
20. Ambulance Performance Standards	Compliance () Non-Compliance ()
20.1 Main Cot Retention	Compliance () Non-Compliance ()
20.2 Static Load Test Ambulance Body Structures.....	Compliance () Non-Compliance ()
20.3 HVAC Performance Tests.....	Compliance () Non-Compliance ()
20.3.3 Heating System	Compliance () Non-Compliance ()
20.3.4 Air Conditioned System	Compliance () Non-Compliance ()
20.3.5 Ventilation System	Compliance () Non-Compliance ()
20.4 Pressure Vessel Retention	Compliance () Non-Compliance ()
20.5 Interior Sound Level Test.....	Compliance () Non-Compliance ()
20.6 Vehicle Weight Distribution	Compliance () Non-Compliance ()
20.7. Centre of Gravity Location	Compliance () Non-Compliance ()
20.8 12 Vdc Electrical System Performance	Compliance () Non-Compliance ()
20.9 Electromagnetic Radiation Suppression.....	Compliance () Non-Compliance ()
20.10 Antennae System.....	Compliance () Non-Compliance ()
20.11 Interior Lighting	Compliance () Non-Compliance ()
20.12 Oxygen System Pressure Test	Compliance () Non-Compliance ()
20.13 Suction Aspiration System Performance Test.....	Compliance () Non-Compliance ()
20.14 Run-in and Road Test	Compliance () Non-Compliance ()
20.15 Body Door Components Test.....	Compliance () Non-Compliance ()
20.16 Emergency Lighting Requirements.....	Compliance () Non-Compliance ()
20.17 Carbon Monoxide Levels	Compliance () Non-Compliance ()
20.18 Load Test for Grab Handles/Rail	Compliance () Non-Compliance ()
20.19 Siren/Public Address System Sound Levels	Compliance () Non-Compliance ()
20.20 Incubator Restraint Load Test	Compliance () Non-Compliance ()

- 20.21.2.1 All installed passenger seat belts.....Compliance () Non-Compliance ()
- 20.21.2.2 All installed patient restraint belts.....Compliance () Non-Compliance ()
- 20.22 10 G Restraint Test..... Compliance () Non-Compliance ()
- 20.23 Occupant Restraint Load Test..... Compliance () Non-Compliance ()
- 20.24 Occupant Head Protection Zone.....Compliance () Non-Compliance ()

PART II – NON-COMPLIANCE DETAILS

Provide sub-section number and provide details. Attach additional information to the Checklist as required.

PART III – Options supplied by Contractor at time of delivery

In this area Contractors are to list all options supplied on unit (base unit will be considered to be a single stretcher configuration, left wall mount). **Attach additional information to the Checklist as required.**

Part IV - CONTRACTOR'S COMPLIANCE CERTIFICATION

Contractor's Name: _____

I certify that this Annex to Version 4.1 of the 'Ontario Provincial Land Ambulance & Emergency Response Vehicle Standard' has been completed accurately and that all areas of non-compliance have been identified.

Company Officer:

(Print Name)

(Signature)

(date)

(Notarized, required for ambulance model certification only)

(date)

PART V- INDIVIDUAL AMBULANCE DETAILS

Vehicle Identification Number: _____

MOHLTC Compliance Certificate Number: _____

Date of Completion (final inspection): _____

Name of Purchaser: _____

ANNEX D

**REMOUNTED AMBULANCES
COMPLIANCE CHECKLIST**

**Ontario Provincial Land Ambulance
& Emergency Response Vehicle
Standard**

Version 4.1 – July 15, 2010

**Emergency Health Services Branch
Ministry of Health and Long-Term Care**

ANNEX D REMOUNTED AMBULANCES

Part I - COMPLIANCE CHECKLIST

This Checklist is to be completed in accordance with sub-section 19.1.3 (6) of the *Standard* and submitted to the Director Emergency Health Services Branch along with the other required documentation for compliance certification. Compliance or non-compliance with each requirement will be noted by (✓). Where a requirement is not applicable (N/A) will be noted.

In instances where any non-compliance is noted within a section then details of the non-compliance will be provided in PART II including the sub-section number

- 1. **Scope of the Standard**..... Compliance () Non-Compliance ()
- 2. **Definitions**..... Compliance () Non-Compliance ()
- 3. **General Requirements of the Ambulance**..... Compliance () Non-Compliance ()
 - 3.8 110v Electrical Power.....Compliance () Non-Compliance ()
- 4. **Ambulance Owners Manual**..... Compliance () Non-Compliance ()
- 5. **Materials**..... Compliance () Non-Compliance ()
- 6. **Exterior Identification**..... Compliance () Non-Compliance ()
- 7. **Construction and Design Details**..... Compliance () Non-Compliance ()
- 8. **Heating, Ventilation and Air Conditioning**.....Compliance () Non-Compliance ()
- 9. **Low Voltage Conversion Electrical System**.....Compliance () Non-Compliance ()
- 10. **Emergency Warning System**.....Compliance () Non-Compliance ()
- 11. **2-Way Radio Installations**.....Compliance () Non-Compliance ()
 - 11.6 Installation of radio equipment..... **Compliance () Non-compliance ()**
- 12. **Oxygen System**.....Compliance () Non-Compliance ()
- 13. **Suction Aspiration System**.....Compliance () Non-Compliance ()
- 14. **Storage Requirements & Design**.....Compliance () Non-Compliance ()
- 15. **Safety Equipment**..... Compliance () Non-Compliance ()

16. Interior Signs and Labels	Compliance () Non-Compliance ()
17. Modular Ambulance Body -Type 1 and 3	Compliance () Non-Compliance ()
18. Ambulance Chassis Specifications	Compliance () Non-Compliance ()
19. Certification of an Ambulance Model	Compliance () Non-Compliance ()
20. Ambulance Performance Standards	Compliance () Non-Compliance ()
20.1 Main Cot Retention.....	Compliance () Non-Compliance ()
20.2 Static Load Test Ambulance Body Structures.....	Compliance () Non-Compliance ()
20.3 HVAC Performance Tests.....	Compliance () Non-Compliance ()
20.3.3 Heating System	Compliance () Non-Compliance ()
20.3.4 Air Conditioning System.....	Compliance () Non-Compliance ()
20.3.5 Ventilation System.....	Compliance () Non-Compliance ()
20.4 Pressure Vessel Retention.....	Compliance () Non-Compliance ()
20.5 Interior Sound Level Test.....	Compliance () Non-Compliance ()
20.6 Vehicle Weight Distribution.....	Compliance () Non-Compliance ()
20.7. Centre of Gravity Location.....	Compliance () Non-Compliance ()
20.8 12 Vdc Electrical System Performance.....	Compliance () Non-Compliance ()
20.9 Electromagnetic Radiation Suppression.....	Compliance () Non-Compliance ()
20.10 Antennae System.....	Compliance () Non-Compliance ()
20.11 Interior Lighting.....	Compliance () Non-Compliance ()
20.12 Oxygen System Pressure Test.....	Compliance () Non-Compliance ()
20.13 Suction Aspiration System Performance Test.....	Compliance () Non-Compliance ()
20.14 Run-in and Road Test	Compliance () Non-Compliance ()
20.15 Body Door Components Test.....	Compliance () Non-Compliance ()
20.16 Emergency Lighting Requirements.....	Compliance () Non-Compliance ()
20.17 Carbon Monoxide Levels.....	Compliance () Non-Compliance ()
20.18 Load Test for Grab Handles/Rail.....	Compliance () Non-Compliance ()
20.19 Siren/Public Address System Sound Levels.....	Compliance () Non-Compliance ()
20.20 Incubator Restraint Load Test.....	Compliance () Non-Compliance ()

Ontario Provincial Land Ambulance & Emergency Response Vehicle Standard	112
20.21.2.1 All installed passenger seat belts.....	Compliance () Non-Compliance ()
20.21.2.2 All installed patient restraint belts.....	Compliance () Non-Compliance ()
20.22 10 G Restraint Test.....	Compliance () Non-Compliance ()
20.23 Occupant Restraint Load Test.....	Compliance () Non-Compliance ()
20.24 Occupant Head Protection Zone.....	Compliance () Non-Compliance ()

ANNEX B TRANSFER OF PATIENT COMPARTMENT MODULE

B2 General Requirements of a Remounted Ambulance.....	Compliance () Non-Compliance ()
B3 Structural Integrity.....	Compliance () Non-Compliance ()
B4 Material Changes.....	Compliance () Non-Compliance ()
B4.1 Seats, Seat Belts, Occupant Restraints.....	Compliance () Non-Compliance ()
B4.2 Compartment Materials.....	Compliance () Non-Compliance ()
B4.3 Exterior Lights.....	Compliance () Non-Compliance ()
B4.4 Body Door Components.....	Compliance () Non-Compliance ()
B5 Certification of Remount.....	Compliance () Non-Compliance ()
B5.2 Any Non-Compliance Conditions.....	Compliance () Non-Compliance ()
B5.3 Testing by Professional Engineer.....	Compliance () Non-Compliance ()
B5.4 Testing by Contractor.....	Compliance () Non-Compliance ()

PART II – NON-COMPLIANCE DETAILS

Provide sub-section number and provide details. Attach additional information to the Checklist as required.

PART III – Options supplied by Contractor at time of delivery

In this area Contractors are to list all options supplied on unit (base unit will be considered to be a single stretcher configuration, left wall mount). **Attach additional information to the Checklist as required.**

Part IV - CONTRACTOR'S COMPLIANCE CERTIFICATION

Contractor's Name: _____

I certify that this Annex to Version 4.1 of the 'Ontario Provincial Land Ambulance & Emergency Response Vehicle Standard' has been completed accurately and that all areas of non-compliance have been identified.

Company Officer:

(Print Name)

(Signature)

(date)

(Notarized, required for ambulance model certification only)

(date)

PART V- INDIVIDUAL AMBULANCE DETAILS

Vehicle Identification Number: _____

MOHLTC Compliance Certificate Number: _____

Date of Completion (final inspection): _____

Name of Purchaser: _____

**This page has been
left
intentionally blank**

ANNEX E

**ERV
COMPLIANCE CHECKLIST**

**Ontario Provincial Land Ambulance
& Emergency Response Vehicle
Standard**

Version 4.1 – July 15, 2010

**Emergency Health Services Branch
Ministry of Health and Long-Term Care**

**ANNEX E
ERV
COMPLIANCE CHECKLIST**

PART I – COMPLIANCE DETAILS

To confirm compliance with Annex A of the *Standard* this Checklist is to be completed and accompany the letter of certification by the Contractor for each unit. Compliance or non-compliance with each requirement will be noted by (X). In instances where any non-compliance is noted, within a section the details of the non-compliance will be provided in the Part 11 including the sub-section number.

- A1. Scope of Annex ACompliance () Non-Compliance ()
- A2. Definitions**Compliance** () **Non-Compliance** ()
- A3. General Requirements of a ERVCompliance () Non-Compliance ()
- A4. Exterior Identification.....Compliance () Non-Compliance ()
- A5. Emergency Warning SystemCompliance () Non-Compliance ()
- A6. 2-Way Radio Installations.....Compliance () Non-Compliance ()
- A6.5 Installation of radio equipment **Compliance** () **Non-Compliance** ()
- A7. Storage.....**Compliance** () **Non-Compliance** ()
- A8. Certification of an ERVCompliance () Non-Compliance ()

PART II – NON-COMPLIANCE DETAILS

Provide sub-section number and provide details. Attach additional information to the Checklist as required.

PART III – Options supplied by Contractor at time of delivery

List all options supplied on unit. Attach additional information to the Checklist as required.

Part IV - CONTRACTOR'S COMPLIANCE CERTIFICATION

Contractor's Name: _____

VIN# of ERV _____

Name of Purchaser: _____

I certify that this Annex to Version 4.1 of the 'Ontario Provincial Land Ambulance & Emergency Response Vehicle Standard' has been completed accurately and that all areas of non-compliance have been identified.

Company Officer:

(Print Name)

(Signature)

(date) _____

ONTARIO PROVINCIAL LAND AMBULANCE & EMERGENCY RESPONSE VEHICLE STANDARD

INDEX

I

110v Electrical power	5, 103, 109
12V	14, 65, 66

A

Accessories.....	4, 34, 71, 85, 95
Air conditioning.....	12, 13, 14, 16, 54, 56, 65, 72
Ambulance body.....	38, 50, 98
Ambulance configuration.....	61
Ambulance performance tests	96
Ambulance type.....	43
Ammeter.....	66
Antenna.....	10, 24, 25, 26, 44, 67, 68, 99, 104, 110
Axle	61, 62, 63

B

Backup warning alarm	19
Battery.....	14, 15, 16, 17, 66, 68
Body.....	2, 3, 6, 11, 21, 36, 38, 40, 44, 50, 71, 72, 88, 97, 98, 103, 104, 110
Body mounting	38
Brakes	15
Breaker.....	17
Bumper	11, 12, 23

C

Cab dome and map lights	18
Certification.....	2, 14, 41, 42, 45, 46, 47, 48, 64, 67, 98, 99, 103, 104, 105, 106, 109, 110, 112, 113
Chassis	2, 3, 5, 13, 14, 37, 38, 40, 43, 45, 55, 62, 64, 68, 85, 95, 97
Clutch.....	59
CMVSS.....	2, 4, 13, 36, 65, 72, 79, 85, 96, 97
Colour	7, 20, 27, 87
Compartments	9, 10, 14, 18, 55, 56, 89
Components.....	4, 20, 30, 43, 46, 51, 57, 72, 80, 88, 97, 98, 104, 111
Contractor.....	2, 13, 14, 38, 41, 42, 43, 44, 45, 46, 50, 61, 64, 67, 71, 79, 90, 96, 98, 99, 105, 112, 118
Controls.....	8, 30, 37, 72
Conversion switches and indicators.....	37
Converted curb weight.....	50, 61, 62, 63
Convex mirrors	36
Cooling.....	13, 59
Cot configuration.....	38
Curb weight.....	50, 61, 62, 63

D

Data.....	24, 43
Definitions	50, 57, 61, 103, 109
Design	4, 9, 19, 24, 36, 37, 50, 85, 87, 95, 103, 109
Dimensions	40, 58
Documents.....	4, 85, 95
Door activated switches	16
Door ajar light	16
Door latches.....	39
Doors.....	8, 9, 11, 16, 30, 33, 35, 36, 37, 39, 52, 53, 55, 56, 59, 72, 75
Drawings, annexes and appendices.....	5
Driver compartment	8, 13, 19, 37, 59, 60, 75
Driver's switch panel	15

E

Electrical.....	14, 18, 37, 40, 41, 65, 66, 71, 103, 109
Electrical ground	40
Electrical load isolation	14
Electrical load rating	18
Electrical system	14, 44, 72, 99, 104, 110
Electrical system performance.....	44, 64, 99, 104, 110
Electromagnetic radiation.....	67
Electromagnetic radiation and suppression	44, 99
Emergency Health Services.....	42, 45, 103, 109
Emergency lighting	19, 20, 44, 72, 87, 98, 104, 111
Emergency response vehicle.....	1, 2, 4, 85
Emergency warning lights.....	15
Engine	9, 14, 15, 54, 56, 59, 60, 64, 66, 67, 72
Exhaust.....	13, 55
Exterior storage doors	16

F

Fan	59, 72
Fenders	22
Fire extinguishers.....	36
Folding stretcher	28, 29, 31
Forward warning device.....	23
Frame	11, 17, 26, 38, 40, 51, 97
Fuse	15, 18

G

General construction	9
Grab rails	35, 76
Gross vehicle weight rating	61, 62

H

Hardware	57
Heating	12, 13, 14, 16, 54
High idle speed	64
Hinges	39, 97
Horn	23, 89
HVAC performance tests	44, 54, 104, 110

I

Ignition system.....	65
----------------------	----

Ontario Provincial Land Ambulance & Emergency Response Vehicle Standard	121
Illumination	16, 17, 18, 68
Incubator receptacles	14, 17
Insulation	6, 9, 19
Interior lighting	44, 68, 98, 104, 110
Interior sound level test	44, 98, 104, 110
Interior surfaces	6
IV hooks	33
L	
Lamps	20, 87, 97
Loading	16
M	
Main cots	30, 49
Maintenance and repair	5
Markings	27
Ministry	42, 45, 46, 47, 86
Mirrors	36
Mobile data terminals	24
N	
National safety mark	41
O	
Occupant	4, 7, 8, 14, 32, 36, 37, 80, 81, 85, 86, 87, 95, 96, 97
Occupant compartments	14
Occupant restraints	97
OEM	3, 4, 5, 6, 10, 11, 12, 13, 14, 15, 16, 22, 36, 40, 45, 50, 55, 56, 61, 62, 64, 66, 72, 85, 89, 95, 97
Ohmeda	17
<u>Oxygen system</u>	27, 44, 69, 99, 103, 104, 109, 110
Oxygen system pressure test	69, 99
P	
Patient compartment	3, 9, 10, 11, 12, 13, 16, 17, 29, 30, 32, 33, 34, 35, 36, 37, 39, 54, 55, 59, 65, 68, 72, 75, 95, 96, 98
Payload allowance	61
Performance standards	38, 41, 43, 44, 46, 90, 98, 99, 104, 110
Performance tests	97
PES	3, 27, 28, 33, 36, 89
Photometric	97
Public address system	23, 44, 77, 89, 98, 104, 111
Purchaser	3, 14, 33, 45, 64, 65, 66, 69, 70
R	
Radio	10, 14, 16, 17, 23, 24, 25, 26, 30, 40, 65, 67, 103, 109
Radio equipment	16, 24, 25
Radio equipment mounting	25
Rear doors	39, 55, 72
Rear facing attendant seat	25, 30, 31, 34, 35
Rear step bumper	11
Rear view mirrors	36
Relays	18
Remount	3, 95, 96, 98, 99
Restraints	44, 79, 96, 98
Roof warning lights	20, 23

S

SAE.....	3, 12, 20, 67, 88, 95
Safety by design	8
Seat belts.....	31, 36, 37, 79, 96
Seats	10, 34, 36, 79, 96
Securing straps.....	9, 33, 89, 96
Side door step	11
Side doors.....	30
Siren speakers	24
Sound level limits.....	60
Spare tire	34
Spare tire storage	34
Special Purpose Ambulance	2, 29
Splices and connections	19
Squad bench	29, 30, 31, 35
Straps.....	9, 33, 40, 89, 96
Stretcher	28, 30, 31, 33, 48
Suction aspiration system	28, 44, 70, 99, 103, 104, 110, 111
Suction outlet.....	28, 30
Suspension system	51

T

Temperature.....	12, 13, 37, 54, 55, 56, 58, 60, 64, 67
Tests	44
12 Volt DC Electrical System Performance	44, 64
Antenna System Test	44
Body Door Components	72
Body Door Components Test	44
Carbon Monoxide Levels	44, 74
Centre of Gravity Location	44, 63
Electromagnetic Radiation and Suppression	44
Emergency Lighting	44, 72
HVAC Performance Tests	44, 54
Incubator Restraint Load Test.....	44
Interior Lighting	44, 68
Interior Sound Level Test.....	44, 59
Load Test for Grab Rail/Handles.....	44, 76
Main Cot Retention.....	30, 44
Oxygen System.....	44, 69
Passenger and Patient Safety Restraints Load Tests	44
Pressure Vessel Retention.....	44, 56, 71
Run-In and Road Test.....	45
Siren/Public Address System.....	44, 77
Static Load Test For Ambulance Body Structures	44, 50
Suction Aspiration System Performance Test	44, 70
Vehicle Weight	44
Transmission.....	15, 55, 56, 60
Type 1	11, 12, 103, 110
Type 2	11, 12
Type 3	2, 12

U

Underhood.....	64, 67
----------------	--------

V

Vehicle weight distribution 61
Voltmeter 16, 66

W

Weight..... 6, 9, 11, 26, 33, 44, 50, 57, 58, 61, 62, 63, 77, 89, 99, 104, 110
Weight distribution 62, 63
Windshield defrosting and defogging system 13
Windshield wipers 65
Wiring 18, 19